

2836 Series Electric Fryers

Service and Parts Manual



This manual is for models that have rounded elements and float switches.



Frymaster/Dean, a member of the Commercial Food Equipment Service Association, recommends using CFESA Certified Technicians.

24-Hour Service Hotline 1-800-551-8633

*** 8196049 ***

February 2005

Please read all sections of this manual and retain for future reference.

NOTICE

This appliance is intended for professional use only and is to be operated by qualified personnel only. A Frymaster/Dean Factory Authorized Service Center (FASC) or other qualified professional should perform installation, maintenance, and repairs. Installation, maintenance, or repairs by unqualified personnel may void the manufacturer's warranty. See Chapter 1 of this manual for definitions of qualified personnel.

NOTICE

This equipment must be installed in accordance with the appropriate national and local codes of the country and/or region in which the appliance is installed.

NOTICE TO U.S. CUSTOMERS

This equipment must be installed in accordance with the appropriate national and local codes of the country and/or region in which the appliance is installed.

NOTICE

Drawings and photos used in this manual are intended to illustrate operational, cleaning and technical procedures and may not conform to onsite management operational procedures.

NOTICE TO OWNERS OF UNITS EQUIPPED WITH COMPUTERS

U.S.

This device complies with Part 15 of the FCC rules. Operation is subject to the following two conditions: 1) This device may not cause harmful interference, and 2) This device must accept any interference received, including interference that may cause undesired operation. While this device is a verified Class A device, it has been shown to meet Class B limits.

CANADA

This digital apparatus does not exceed the Class A or B limits for radio noise emissions as set out by the ICES-003 standard of the Canadian Department of Communications.

Cet appareil numérique n'émet pas de bruits radioélectriques dépassant les limites de classe A et B prescrites dans la norme NMB-003 édictée par le Ministre des Communications du Canada.

 DANGER

Improper installation, adjustment, maintenance or service, and unauthorized alterations or modifications can cause property damage, injury, or death. Read the installation, operating and service instructions thoroughly before installing or servicing this equipment.

 **DANGER**

The front ledge of the fryer is not a step. Do not stand on the fryer. Serious injury can result from slips or contact with the hot oil.

 **DANGER**

Do not store or use gasoline or other flammable vapors and liquids in the vicinity of this or any other appliance.

 **DANGER**

The crumb tray in fryers equipped with a filter system must be emptied into a fireproof container at the end of frying operations each day. Some food particles can spontaneously combust if left soaking in certain shortening material. Additional information can be obtained in the filtration manual included with the system.

 **WARNING**

No structural material on the fryer should be altered or removed to accommodate placement of the fryer under a hood. Questions? Call the Frymaster/Dean Service Hotline at 1-800-551-8633.

 **WARNING**

Do not bang fry baskets or other utensils on the fryer's joiner strip. The strip is present to seal the joint between the frypot. Banging fry baskets on the strip to dislodge shortening will distort the strip, adversely affecting its fit. It is designed for a tight fit and should only be removed for cleaning.

NOTICE

IF, DURING THE WARRANTY PERIOD, THE CUSTOMER USES A PART FOR THIS ENODIS EQUIPMENT OTHER THAN AN UNMODIFIED NEW OR RECYCLED PART PURCHASED DIRECTLY FROM FRYMASTER/DEAN, OR ANY OF ITS AUTHORIZED SERVICE CENTERS, AND/OR THE PART BEING USED IS MODIFIED FROM ITS ORIGINAL CONFIGURATION, THIS WARRANTY WILL BE VOID. FURTHER, FRYMASTER/DEAN AND ITS AFFILIATES WILL NOT BE LIABLE FOR ANY CLAIMS, DAMAGES OR EXPENSES INCURRED BY THE CUSTOMER WHICH ARISE DIRECTLY OR INDIRECTLY, IN WHOLE OR IN PART, DUE TO THE INSTALLATION OF ANY MODIFIED PART AND/OR PART RECEIVED FROM AN UNAUTHORIZED SERVICE CENTER.



**2836 Series Electric Fryers
Service & Parts Manual**

TABLE OF CONTENTS

	Page #
1. SERVICE PROCEDURES.....	1-1
1.1 General.....	1-1
1.2 Replace Computer/Controller.....	1-1
1.3 Replace Interface Board.....	1-2
1.4 Replace Transformer.....	1-3
1.5 Replace Temperature Probe.....	1-3
1.6 Replace Heating Element.....	1-6
1.7 Replace High-Limit.....	1-8
1.8 Replace Frypot.....	1-9
1.9 Replace Contactor (Latching or Heating).....	1-10
1.10 Built-in Filter System Service Procedures.....	1-10
1.11 Basket Lift Service Procedures.....	1-12
1.12 Electric Interface Board Diagnostic Chart.....	1-15
1.13 Probe Resistance Chart.....	1-16
1.14 Element Wattage/Amperage Calculation Charts.....	1-16
1.15 Wiring Diagrams, Main – 480V (120V Controls).....	1-17
1.16 Wiring Diagrams, Modular Basket Lifts.....	1-18
1.17 Wiring Diagrams, 480V Systems With Built-in Filtration.....	1-19



**2836 Series Electric Fryers
Service & Parts Manual**

TABLE OF CONTENTS (CONT.)

	Page #
2. PARTS LIST	2-1
2.1 Accessories	2-1
2.2 Basket Lift Assembly (Modular) and Related Components	2-2
2.3 Cabinetry and Related Components	2-5
2.3.1 Cabinetry	2-5
2.3.2 Door Components	2-7
2.3.3 Dump Station Components	2-8
2.4 Computer and Related Components	2-9
2.5 Contactor and Power Cord Box Assembly	2-10
2.6 Component Box Assembly	2-12
2.7 Filter Pan and Related Components	2-13
2.8 Frypot and Related Components	2-14
2.8.1 Frypot and Drain Valve Components	2-14
2.8.2 Oil Disposal Wand	2-15
2.8.3 Elements and Related Components	2-16
2.9 Oil Return Assembly	2-18
2.10 Filter Pump Assembly	2-19

2836 SERIES ELECTRIC FRYERS

CHAPTER 1: SERVICE PROCEDURES

1.1 General

Before performing any maintenance on your Frymaster/Dean Ultimate Electric fryer, you must disconnect the electrical power supply.

When electrical wires are disconnected, it is recommended that they be marked in such a way as to facilitate reassembly.

⚠ DANGER

Hot cooking oil or shortening will cause severe burns. Never attempt to move this appliance when filled with hot cooking oil or shortening, or to transfer hot cooking oil or shortening from one container to another.

⚠ DANGER

This equipment should be unplugged when servicing, except when electrical circuit tests are required. Use extreme care when performing such tests.

This appliance may have more than one electrical power supply connection point. Disconnect all power cords before servicing.

Inspection, testing and repair of electrical components should be performed by an authorized service agent only.

1.2 Replace Computer/Controller

1. Unscrew and remove two control panel screws on control panel front. Swing the panel open from the top.
2. Unplug wiring harness at plug on back of controller (arrow). Unplug controller ground wire from controller (circle).
3. Remove the control panel/controller by lifting the assembly from the hinged slots in the control-panel frame.
4. Reverse procedures to install new controller.



Wire harness/connector and ground wire on controller back.

1.3 Replace Interface Board

1. Unplug all power cords. Perform Procedure 1.2, Steps 1-4, Replace Computer/Controller.
2. Unplug wire harness from the interface board (arrow). Remove all wiring from the terminals of the interface board, ensuring that each wire is marked for reattachment.

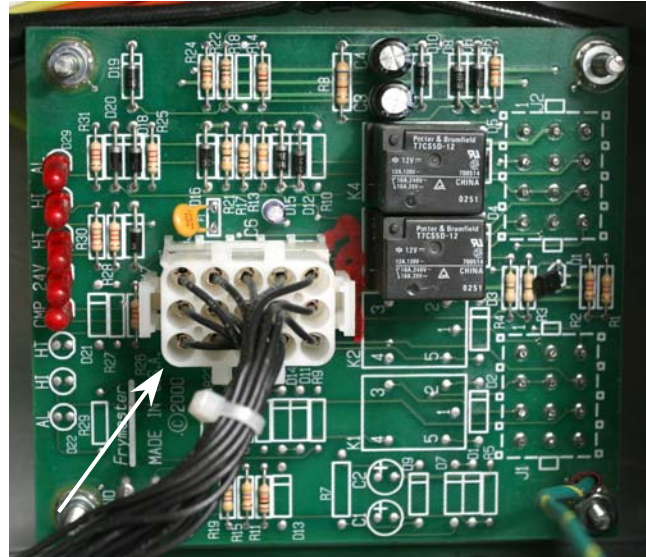

Wire harness/connector.

3. Remove the nuts from each corner of the interface board and slide the board from the studs. Unplug connectors J1 and J2, mark and unplug all other wiring on rear of the interface board. Ensure that standoffs remain in place on studs, prior to installing new interface board. Install the new interface board by reversing the previous procedures. Ensure that wire harnesses are connected to back of interface board prior to securing interface board. Also, ensure that wiring and wire harnesses are connected to the proper terminals.

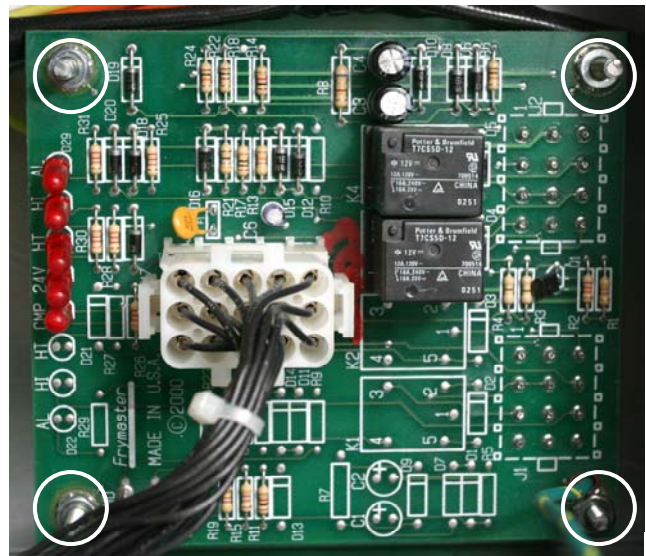

Nuts securing interface board (circles).

1.4 Replace Transformer

1. Unplug all power cords. Perform Procedure 1.2, Steps 1-4, Replace Computer/Controller.
2. Hold new transformer up to old transformer to be replaced and disconnect one wire at a time from old and connect to new.
3. Remove the screws that secure the transformer to the component box.
4. Install the new transformer by reversing the preceding procedures. Make sure you reconnect the wiring to the proper terminals and the harnesses to the correct connectors.

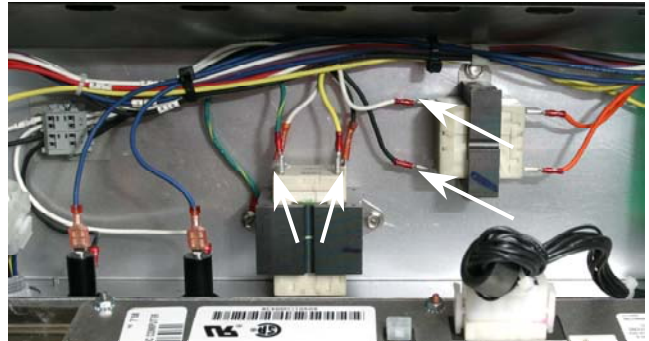

Disconnect wiring from the transformer being replaced and connect to new transformer.

1.5 Replace Temperature Probe

1. Unplug fryer from the electrical source.
2. Drain the cooking oil from the frypot.
3. Remove the fryer from the exhaust hood to gain access to the rear of the fryer.
4. If unit is equipped with modular basket lift, remove basket lift assembly and set aside.
5. Remove the screws from the top cap and back cover(s). Set the cover(s), top cap and screws aside.

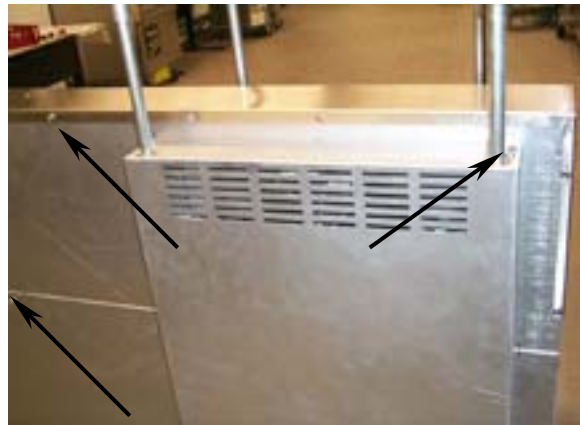

Screws securing back covers, top cap and basket lift assembly.

6. Disconnect the wire harness containing the probe wiring (arrows). It may be necessary to remove the wire ties.

7. Use a pin-pusher (P/N 806-4855 or P/N 807-0928—see Section 1.7) to remove the red and white probe wires from the connector. Note probe pin location in plug. Pull the probe wires out of the insulation.

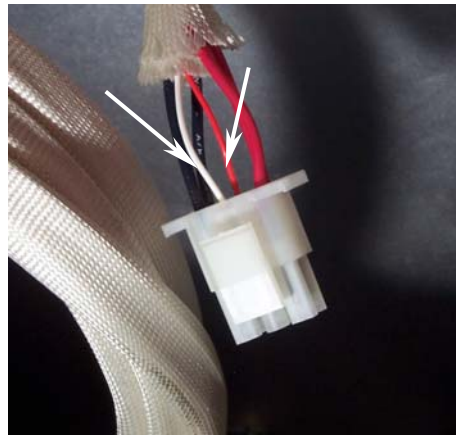

Use a pin-pusher to remove probe wires from connector (arrows).

8. Remove the screw(s) securing the probe bracket to the element. Remove the metal wraps securing the probe to the element.

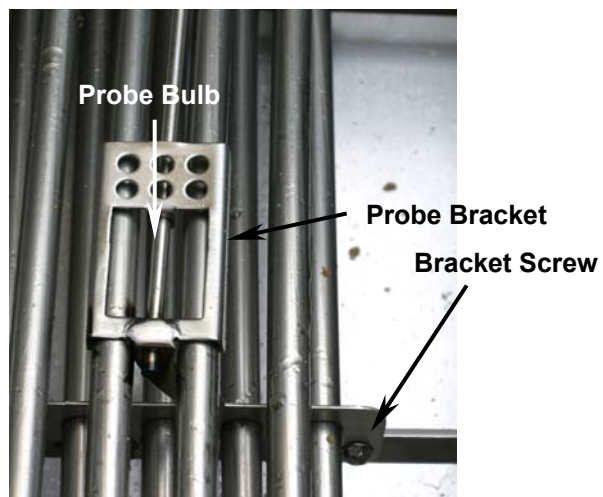

Remove probe bracket screw and bracket to remove probe.

9. Remove the probe bracket and the securing components from the probe bulb and element. Thread the probe wire through the hole (arrow) in the tilt plate assembly and remove the probe.



Pull old probe wire through grommet to remove probe.

10. Thread the new probe wire through the hole in tilt plate. Place the new temperature probe assembly onto the element and secure with the bracket and screws removed earlier. Clip the probe onto the rear of the element (arrow) in two places. The temperature probe assembly should be oriented in the same manner as the probe being replaced.

11. Thread the probe wires into the harness insulation. Note the pin positions and insert pins in the connector. Reconnect the harness and secure with a wire-tie.

12. Lower the element into the frypot with the lift handle.

13. Install the back covers, basket lift assembly, and top cap and secure with screws.



Secure probe bulb to the element back in two places with metal wire wrap (arrow).



Install the cabinet backs, basket lift assembly, and top cap after probe installation is complete.

1.6 Replace Heating Element

1. Perform Procedure 1.5, Replace Temperature Probe, Steps 1-7.

2. Unplug the element connectors for the element being removed (right element- 6-pin harness connector; left element- 9-pin harness connector). Remove the element wires from the connector. Press down on either side of the connector while pulling up on the top portion. The connector will open from the top. Note wiring configuration in connector before removing element wire pins. Pull all wires from the connector.

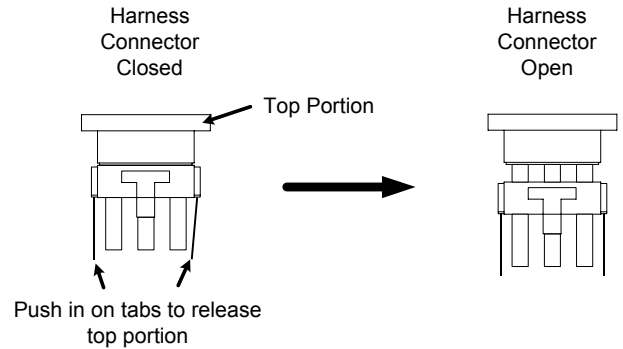

3. Loosen conduit connector and pull element wires through conduit.

4. Remove the screws securing the temperature probe bracket from the element. Remove the probe clamp (metal wire-wrap). Set the temperature probe and probe-securing components aside.

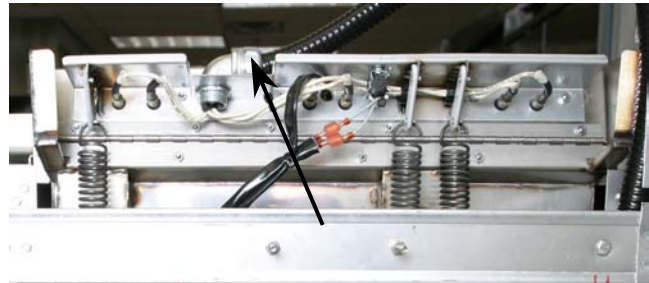

Loosen conduit connector here.

NOTE: Temperature probe removal is not required if the left element is being replaced.

5. Disconnect the element springs from the tilt brackets.

6. Remove the element clamps and hardware before removing mounting-screws and nuts on the defective element. Remove all wire-ties securing element wiring, and then remove element from frypot.

7. Install the replacement element in the frypot and secure with the mounting hardware.

8. Reinstall the temperature probe and probe-bracket components onto the replacement element.

9. Route the element leads (terminals) to the rear of the fryer

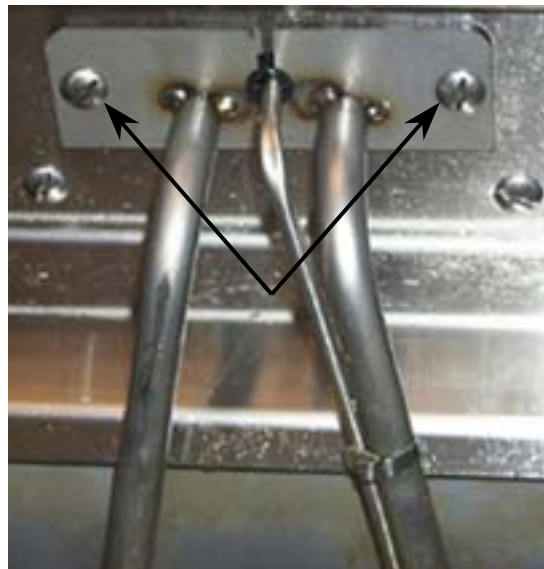

Element mounting screws on tilt-plate front.

10. Secure element wiring with wire-ties.
11. Route the element wires through the conduit and tighten conduit connector.
11. When replacing the left element (as viewed from the rear of the fryer), use the 9-pin connector, inserting the leads from the replacement element. Ensure the pin numbers match the numbers of the defective element wires. When all pin terminals have been fully inserted, close the connector by sliding the halves together until the tabs snap back into place (reverse procedure in this section, Step 2). Check wire numbers to ensure correct wiring of the replacement element.

When replacing the right element (as viewed from the rear of the fryer), follow the above procedure, inserting pin terminals into the corresponding holes in the 6-pin connector.

12. Connect the connectors, ensuring the latches lock in place (arrow).
13. Install the temperature probe wires (marked for re-assembly) in the corresponding pin locations.
14. Reconnect the element springs to the tilt brackets
15. Install the back covers, basket lift assembly, and top cap and secure with screws.
16. Position fryer under exhaust hood.

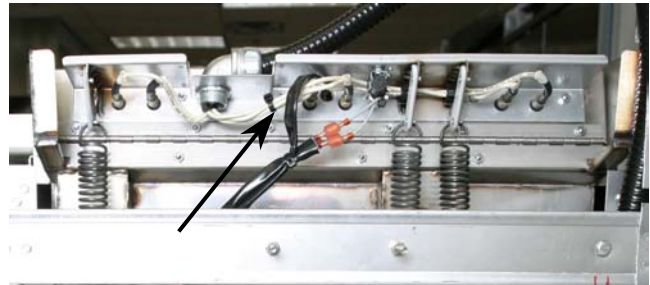

Ensure that the wires are properly routed and secured.

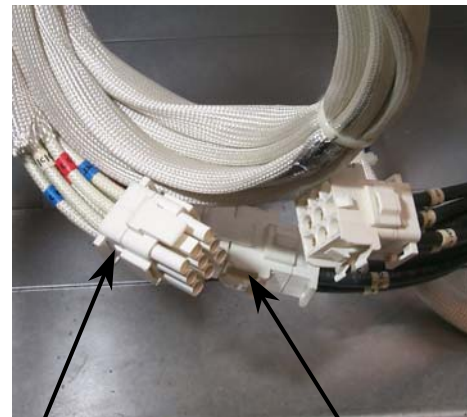

Left Element—
9-Pin Connector

Right Element—
6-Pin Connector

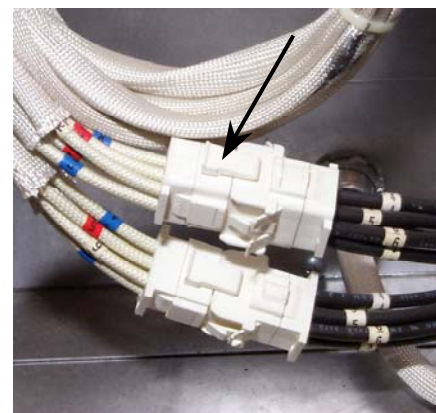

Ensure the connection is complete and the latches (arrow) are locked in place.

1.7 Replace High-Limit

1. Perform Procedure 1.5, Replace Temperature Probe, Steps 1-4.
2. Disconnect the wire harness containing the high-limit wires.
3. Use a pin-pusher (P/N 806-4855 or P/N 807-0928) to remove the two high-limit wires from the wire harness connector (arrows). Note pin location in connector before removing wires.
4. Remove the high-limit from the frypot using an open-end wrench or other suitable tool.
5. Apply Loc-Tite PST 567 sealant to the replacement high-limit threads.
6. Screw the replacement high-limit into the frypot and tighten to 170-180 inch-pounds torque. DO NOT OVERTIGHTEN.
7. Insert the replacement high-limit wires into the connector, ensuring each wire is in the correct hole..
8. Reconnect the high-limit wire-harness connector.
9. Install and secure the back cover(s).
10. Return fryer to operation.

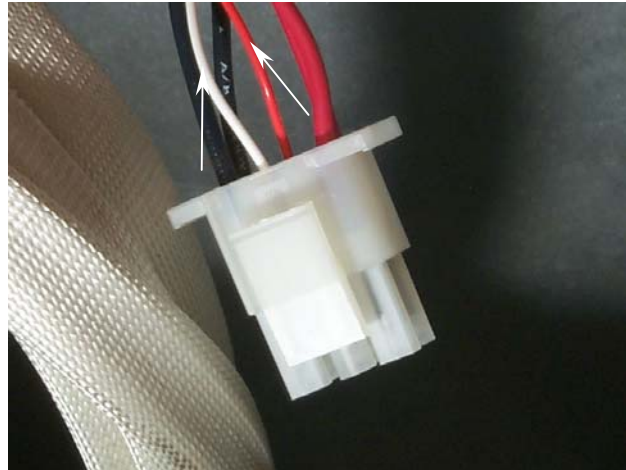

Using a pin-pusher, remove two high-limit wires (arrows) from connector.



Place wrench here when removing and installing high-limit.

1.8 Replace Frypot

1. Perform Procedure 1.5, Replace Temperature Probe, Steps 1-7.
2. Perform Procedure 1.2, Replace Computer/Controller, Steps 1-3.
3. Perform Procedure 1.7, Replace High-Limit, Steps 1-4.
4. Disconnect the element wire harnesses.
5. If the fryer has a built-in filtration system, remove all the plumbing from the frypot, including oil-return and drain plumbing.
6. Remove the screws securing the frypot to the front frame of the fryer.
7. Carefully lift the frypot from the cabinet.
8. Remove the drain valve from the old frypot and install on the new frypot.
9. Apply Loc-Tite Sealant PST 567 to the high-limit threads. Install high-limit into the new frypot.
10. Disconnect the tilt plate springs from the old frypot.
11. Remove the securing screws from the tilt plate. Lift the tilt plate/heating element assembly from the old frypot and install on the new frypot.
12. Follow the preceding steps in reverse to install the new frypot into the fryer.
13. NOTE: Apply Loc-Tite Sealant PST 567 to all pipefittings prior to installation.

1.9 Replace Contactor (Latching or Heating)

1. Remove filter pan.
2. Remove cover to contactor box.
3. Identify faulty contactor. Remove all wiring connected to the contactor terminals (circles) inside the component box. Tape wire-pairs together and mark each wire-set or wire for reassembly.
4. Remove contactor-mounting screws (arrow) and remove the contactor.
5. Install the new contactor and connect the wiring removed in Step 3.

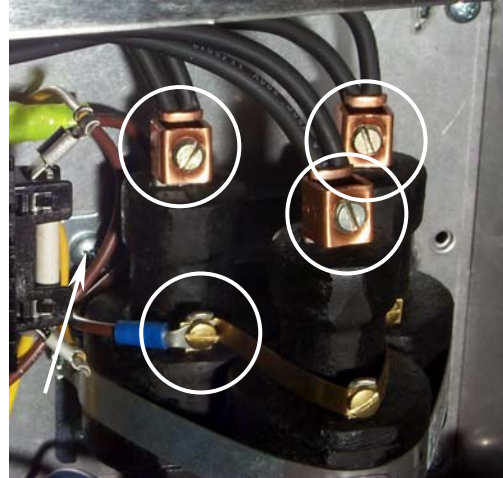

Remove contactor-mounting screws after removing all wiring from the contactor (circles).

1.10 Built-in Filter System Service Procedures

Troubleshooting Built-In Filtration Systems

One of the most common errors is placing the filter paper on the bottom of the filter pan rather than over the filter screen.

CAUTION

Ensure that the paper support screen is in place prior to filter paper placement and filter pump operation. Improper screen placement is the major cause of filter system malfunction.

Whenever the complaint is "the pump is running, but no oil is being filtered", check the installation of the filter paper, and ensure that the correct size is being used. While you are checking the filter paper, verify that the O-rings on the supply line connection are present and in good condition. Missing or worn O-rings allow the pump to take in air, decreasing its efficiency. In addition, oil leaks into the fryer and on the floor each time a frypot is filtered.

If the pump motor overheats, a circuit breaker will trip and the motor will not start until the breaker is reset. If the pump motor does not start, press the white reset button located under the component box, inside the cabinet.

If the pump starts after resetting the breaker, then something is causing the motor to overheat. A major cause of overheating is when several frypots are filtered sequentially, thus overheating the pump and motor. Allow the pump motor to cool at least 30 minutes before resuming operation, and allow time for the motor to cool between sequential frypot filtering.

Pump overheating can be caused by:

- Solidified shortening in the pan or filter lines,
- or
- Attempting to filter unheated oil or shortening.

Cold oil and shortening are more viscous, causing the pump motor to load up and overheat. Always filter with the oil or shortening at operating temperature [$\sim 350^{\circ}\text{F}$ (177°C)].

If the motor runs but the pump does not, there is a blockage in the pump. Incorrectly sized or installed paper/pads will allow food particles and sediment to pass through the filter pan and into the pump. When sediment enters the pump, the gears bind, causing the motor to overload, again tripping the thermal overload. Shortening that has solidified in the pump will also cause it to seize, with the same result.

A pump seized by debris or hard shortening must be disassembled, cleaned, and then reassembled before continuing use. Use the following procedure:

1. Disconnect power to the filter system.
2. Remove the front cover of the pump to access the gears inside (see illustration below- 8-GPM pump shown), if the pump is accessible while still inside the cabinet.

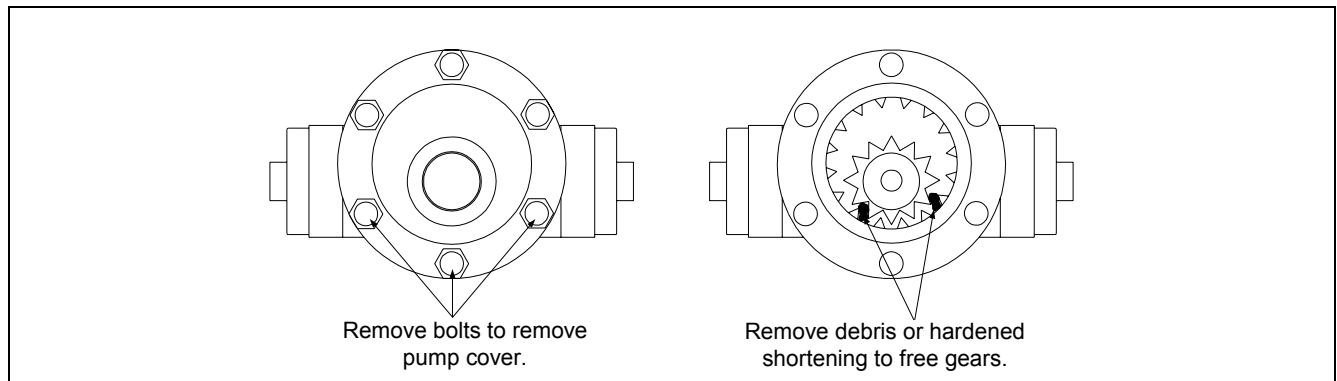

3. If the front cover is not accessible, the pump must be removed from the pump motor (remove input/output plumbing from the pump prior to removing pump). Remove three setscrews from the pump-shaft housing to disengage the pump from the motor. Remove the gears and thoroughly clean all internal components. Ensure the inside of the pump housing is free of any debris or hardened shortening before reassembling. *Failure to completely clean the inside housing and ring gear will cause gear binding after reassembly.*

Filter paper/pads that are the wrong size or installed incorrectly will also allow food particles and sediment to pass through and clog the suction tube in the bottom of the filter pan. Particles large enough to block the suction tube may indicate that the crumb tray is not being used.

1.11 Basket Lift Service Procedures

Ultimate Electric Series fryers may optionally be equipped with automatic basket lifts to ensure uniform cooking times. Electric fryers can be equipped with "modular" or "bell-crank" basket lifts.

A **modular basket lift** (illustrated) consists of a toothed rod to which the basket lift arm is attached, a reversible-drive gear motor and a pair of roller-activated microswitches. The gear motor engages the teeth in the rod, moving it up or down, depending upon the direction of rotation of the motor. Microswitches at the upper and lower limits of movement stop the motor when the basket is in the full up or full down position.

Timing circuitry in the controller initiates and stops basket lift operation depending upon the variables programmed by the operator. When the product button is pressed, or the manual control is activated, the timing circuitry activates a coil in the basket lift relay to supply power to the lower microswitch. The microswitches stop the motor at the lift's upper and lower travel limits and reverse the direction of current flow thus reversing the motor direction.

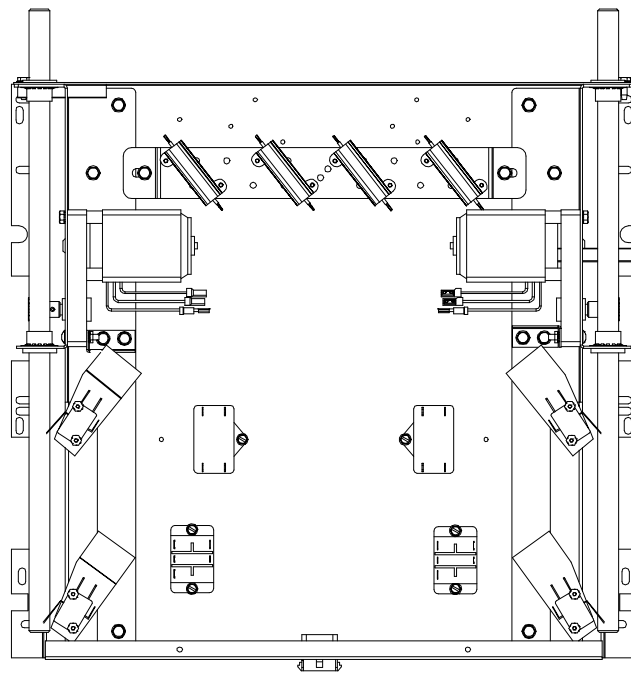

Modular Basket Lift Assembly (Typical).

Simplified Schematic

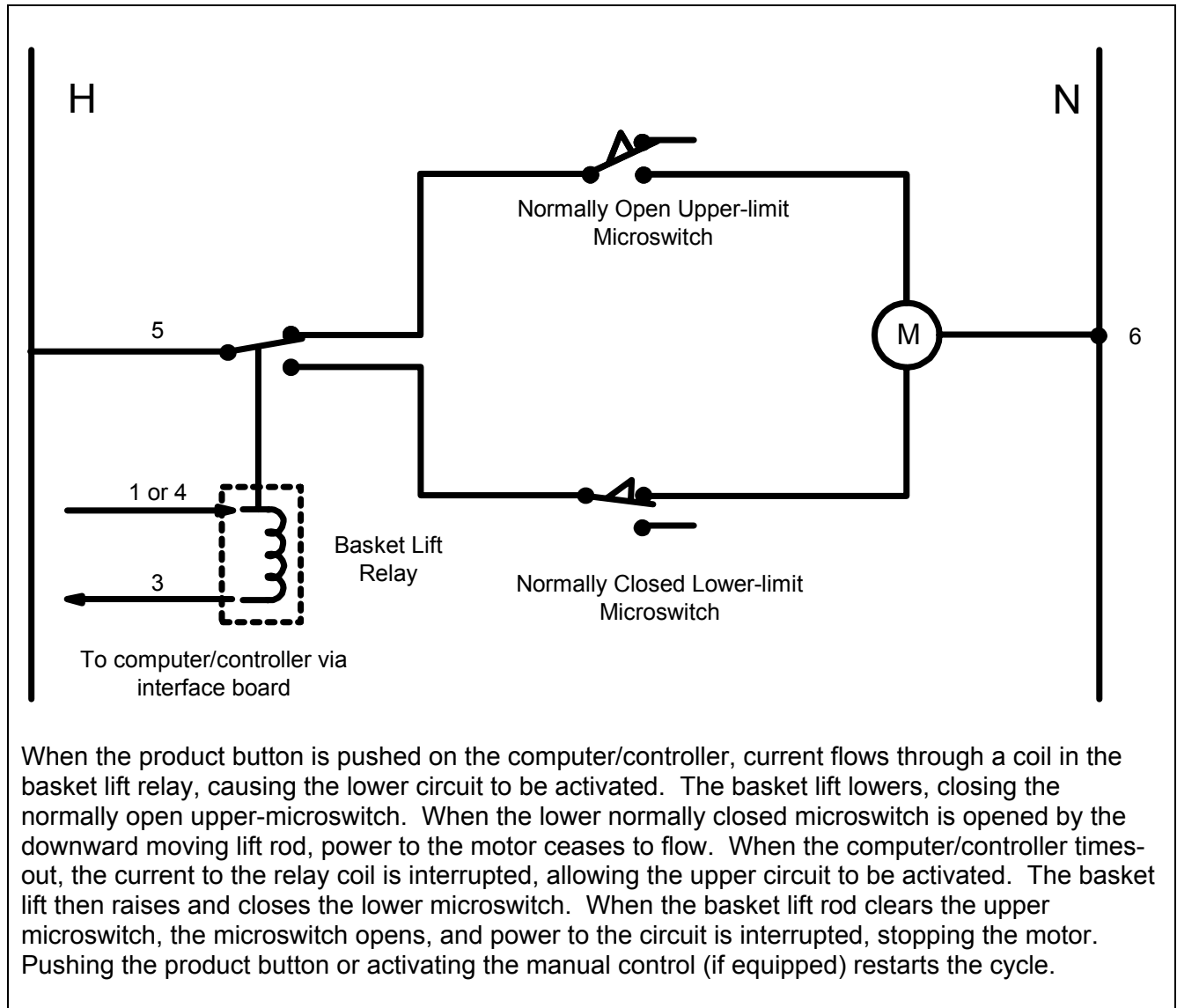

Problems with the modular basket lift design can be grouped into three categories:

- Binding/jamming problems
- Motor and gear problems
- Electronics problems

BINDING/JAMMING PROBLEMS

Noisy, jerky or erratic movement of the lifts is usually due to lack of lubrication of the rods and their bushings. Apply a light coat of Lubriplate or similar lightweight white grease to the rod and bushings to correct the problem.

With the modular basket lift, another possible cause of binding is improper positioning of the motor, which prevents the gear from correctly engaging the teeth in the rod. To correct the problem, loosen the screws that hold the motor in place and move it forward or backward until the rod has just enough slack to be rotated slightly.

MOTOR AND GEAR PROBLEMS

With the modular basket lift, the most likely problem to be encountered in this category is erratic motion of the lift due to a worn drive gear. Failure to keep the lift rod and bushings properly lubricated will cause unnecessary wear of the gear. The problem is corrected by replacing the worn gear.

If the lift cycles correctly but fails to remain in the up position (i.e., goes up, but then slowly settles back down into the frypot), the problem is a failed motor brake. The motor must be replaced.

If power is reaching the motor but the motor fails to run, the motor is burned out and must be replaced.

ELECTRONICS PROBLEMS

Within this category are problems associated with the relays, microswitches, capacitors, resistors, interface board, wiring, and controls. The most common problem in this category is a lift that continuously travels up and down. This is usually caused by a microswitch that is out of adjustment.

Troubleshooting the electronics of a modular-type basket lift is simply a process of verifying current flow through the individual components up to and including the motor. Using a multimeter set to the 250 VAC range, check the connections on both sides of the component for the presence of the applied line voltage. The accompanying simplified wiring diagrams identify the components and wiring connection points.

1.12 Electric Interface Board Diagnostic Chart

The following diagram and charts provide ten quick system checks that can be performed using only a multimeter.

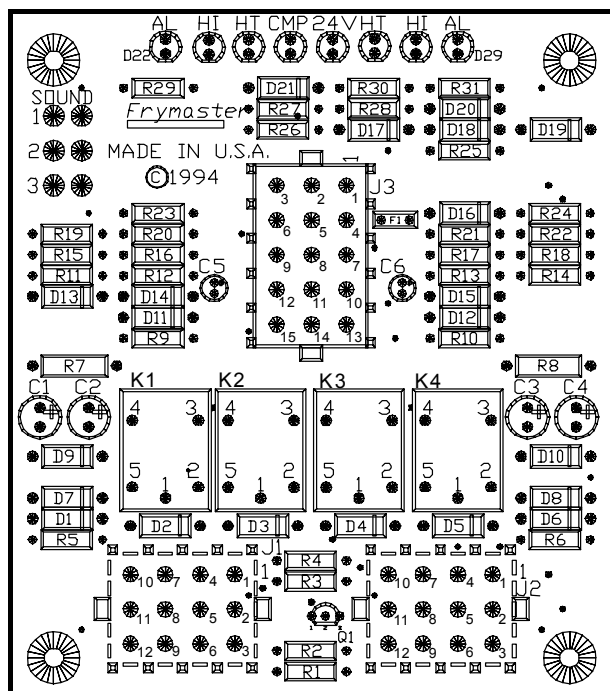

Note: The sealed relays are not replaceable. If a relay fails, the interface board must be replaced.

Diagnostic LED Legend

CMP indicates power from 12V transformer
24 indicates power from 24V transformer
HI (RH) indicates output (closed) from right latch relay
HI (LH) not applicable to Ultimate Electric fryers
HT (RH) indicates output from right heat relay
HT (LH) not applicable to Ultimate Electric fryers
AL (RH) indicates output (open) from right latch relay
AL (LH) not applicable to Ultimate Electric fryers

Meter Setting	Test	Pin	Pin	Results
12 VAC Power	50 VAC Scale	1 of J2	3 of J2	12-16 VAC
24 VAC Power	50 VAC Scale	2 of J2	Chassis	24-30 VAC
*Probe Resistance	R X 1000 OHMS	11 of J2	12 of J2	See Chart
Hi-Limit Continuity	R X 1 OHMS	7 of J2	4 of J2	0 - OHMS
Latch Contactor Coil	R X 1 OHMS	8 of J2	Chassis	3-10 OHMS
Heat Contactor Coil	R X 1 OHMS	9 of J2	Chassis	18-25 OHMS

***Disconnect 15-Pin harness from the computer/controller before testing the probe circuit.**

1.13 Probe Resistance Chart

Use the chart below when testing temperature probes and probe circuits for proper operation.

Probe Resistance Chart																	
F	OHMS	C	F	OHMS	C	F	OHMS	C	F	OHMS	C	F	OHMS	C	F	OHMS	C
60	1059	16	130	1204	54	200	1350	93	270	1493	132	340	1634	171			
65	1070	18	135	1216	57	205	1361	96	275	1503	135	345	1644	174			
70	1080	21	140	1226	60	210	1371	99	280	1514	138	350	1654	177			
75	1091	24	145	1237	63	215	1381	102	285	1524	141	355	1664	179			
80	1101	27	150	1247	66	220	1391	104	290	1534	143	360	1674	182			
85	1112	29	155	1258	68	225	1402	107	295	1544	146	365	1684	185			
90	1122	32	160	1268	71	230	1412	110	300	1554	149	370	1694	188			
95	1133	35	165	1278	74	235	1422	113	305	1564	152	375	1704	191			
100	1143	38	170	1289	77	240	1432	116	310	1574	154	380	1714	193			
105	1154	41	175	1299	79	245	1442	118	315	1584	157	385	1724	196			
110	1164	43	180	1309	82	250	1453	121	320	1594	160	390	1734	199			
115	1174	46	185	1320	85	255	1463	124	325	1604	163	395	1744	202			
120	1185	49	190	1330	88	260	1473	127	330	1614	166	400	1754	204			
125	1195	52	195	1340	91	265	1483	129	335	1624	168	405	1764	207			

1.14 Element Wattage/Amperage Calculation Charts

Use the charts below when changing voltages or determining amperage for a given element configuration.

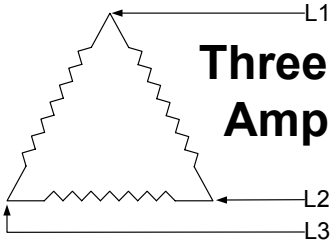

Three Phase Amperage

To determine Three Phase Amperage, solve for Single Phase first:

$$\frac{\text{Wattage}}{\text{Voltage}} = \text{Single Phase Amps}$$

Then divide the Single Phase Amperage by 1.73 to determine Three Phase Amperage.

Example:

$$\frac{17,000\text{W}}{240\text{V}} = \frac{70.833 \text{ Amps}}{1.73}$$

= 40.944 Amps per Phase

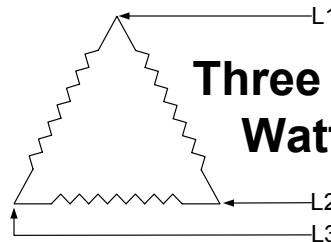

Three Phase Wattage

To compute the New Wattage Rating of an element if a different voltage is applied, use the following formula:

$$\left[\frac{\text{New Voltage}}{\text{Old Voltage}} \right]^2 \times \text{kW Listed} = \text{New Wattage Rating}$$

Example:

If 208V supply is applied to a 17 kW element rated for 240V, the calculation is as follows:

$$\left[\frac{208\text{V}}{240\text{V}} \right]^2 \times 17,000 \text{ Watts} = 12.77 \text{ kW}$$

1.15 Wiring Diagrams, Main - 480V (120 V Controls)

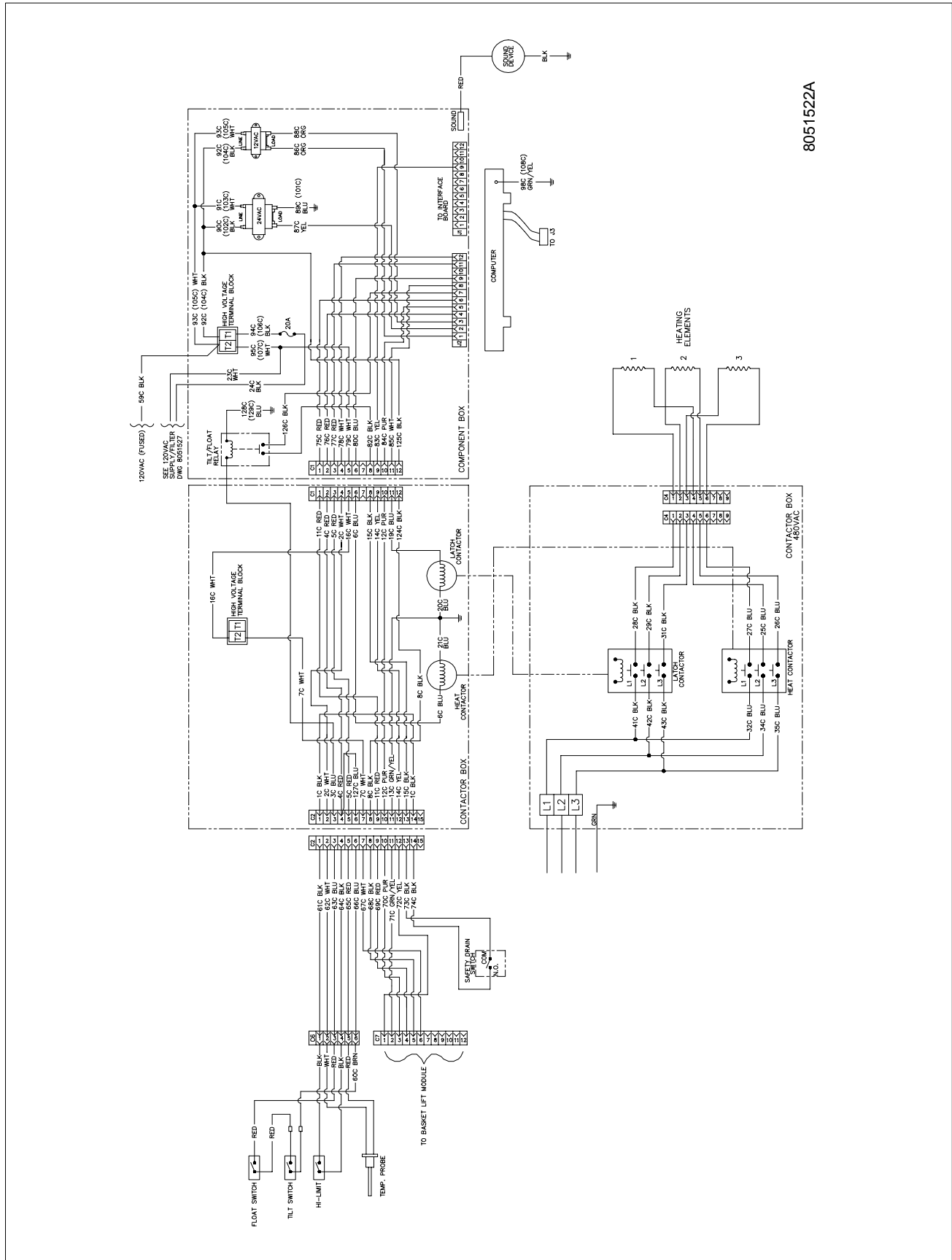

8051522A

1.16 Wiring Diagrams, Modular Basket Lifts

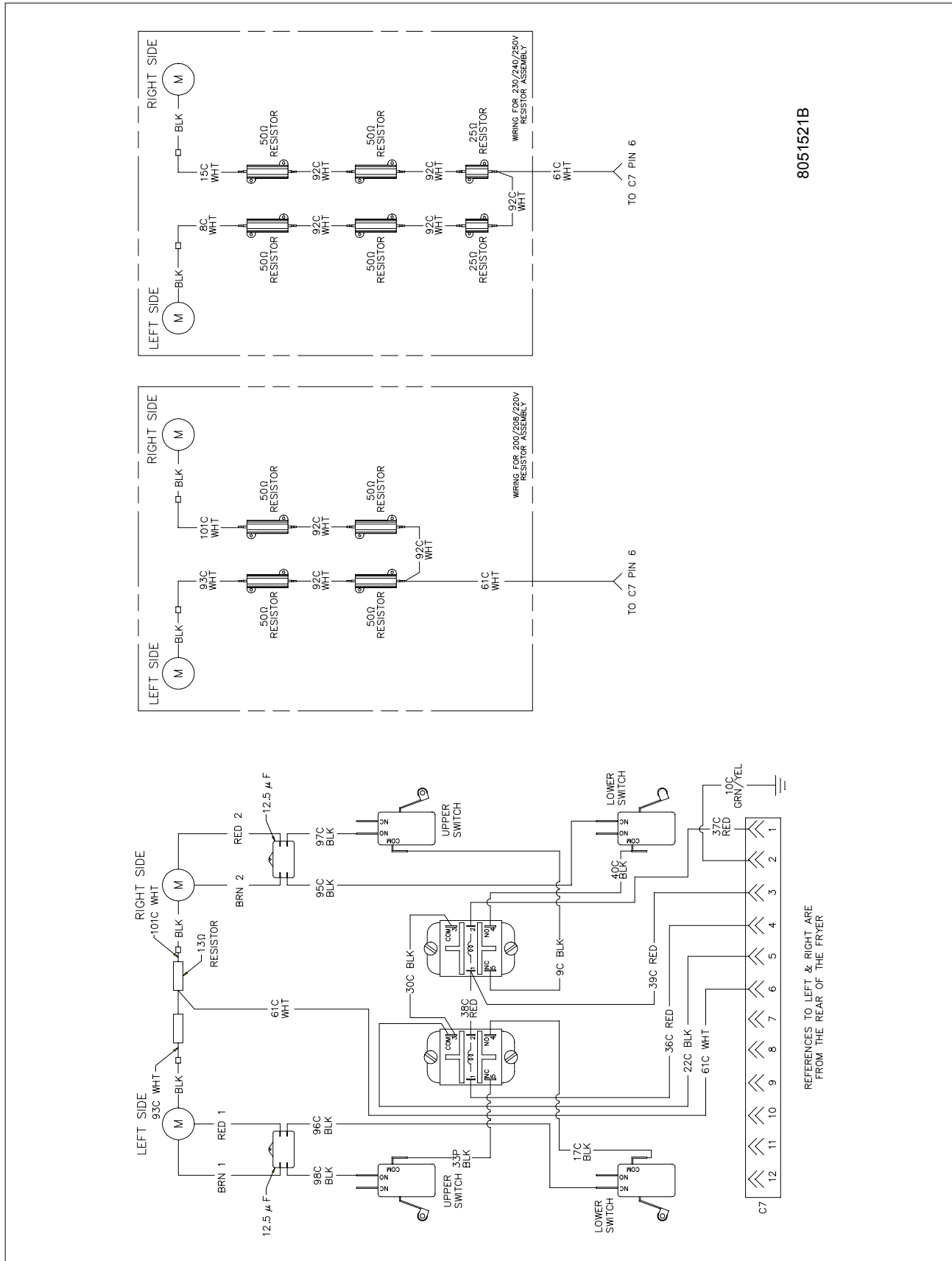

8051521B

1.17 Wiring Diagrams: 480V Systems With Built-in Filtration

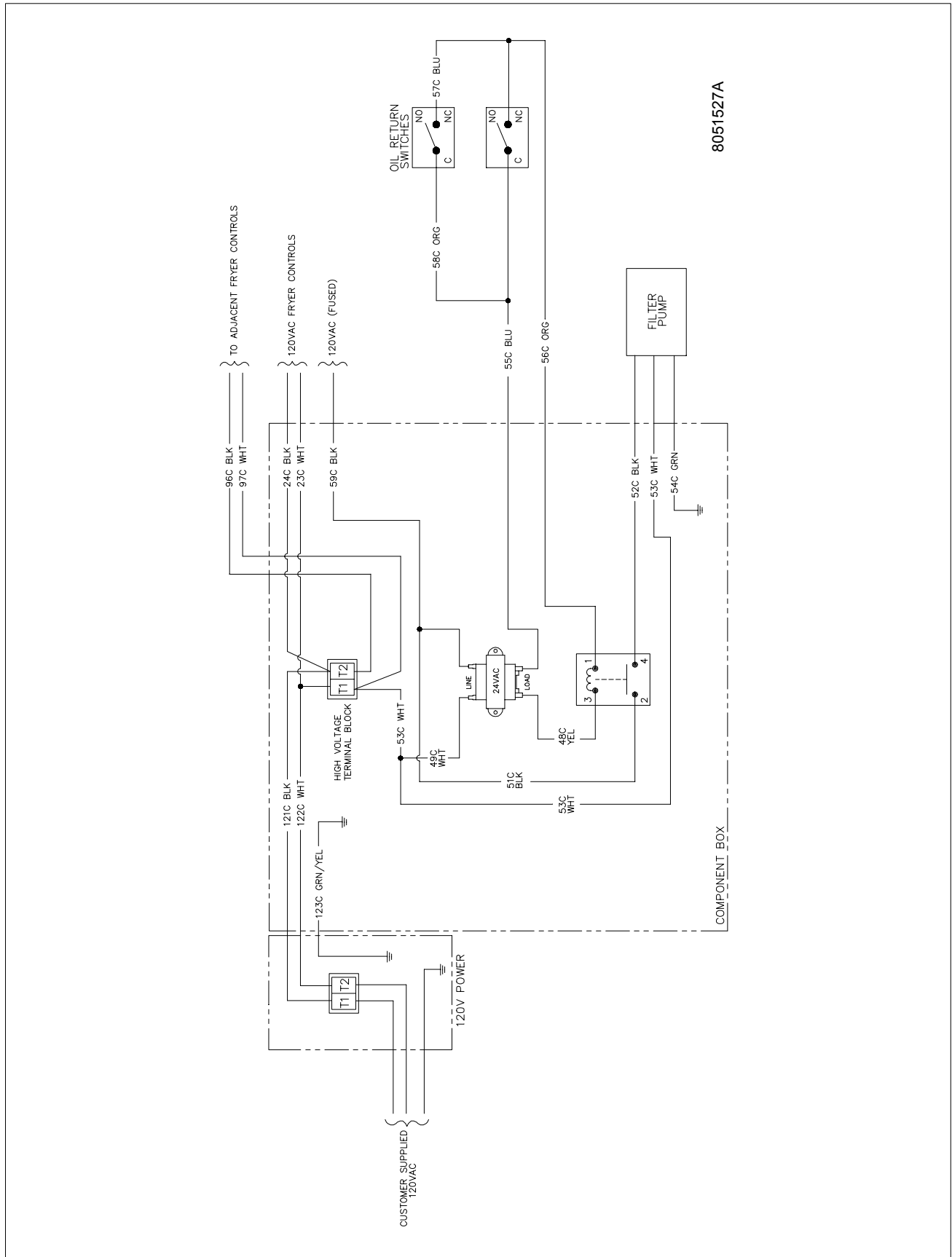

8051527A

2836 SERIES ELECTRIC FRYERS

CHAPTER 2: PARTS LIST

2.1 Accessories

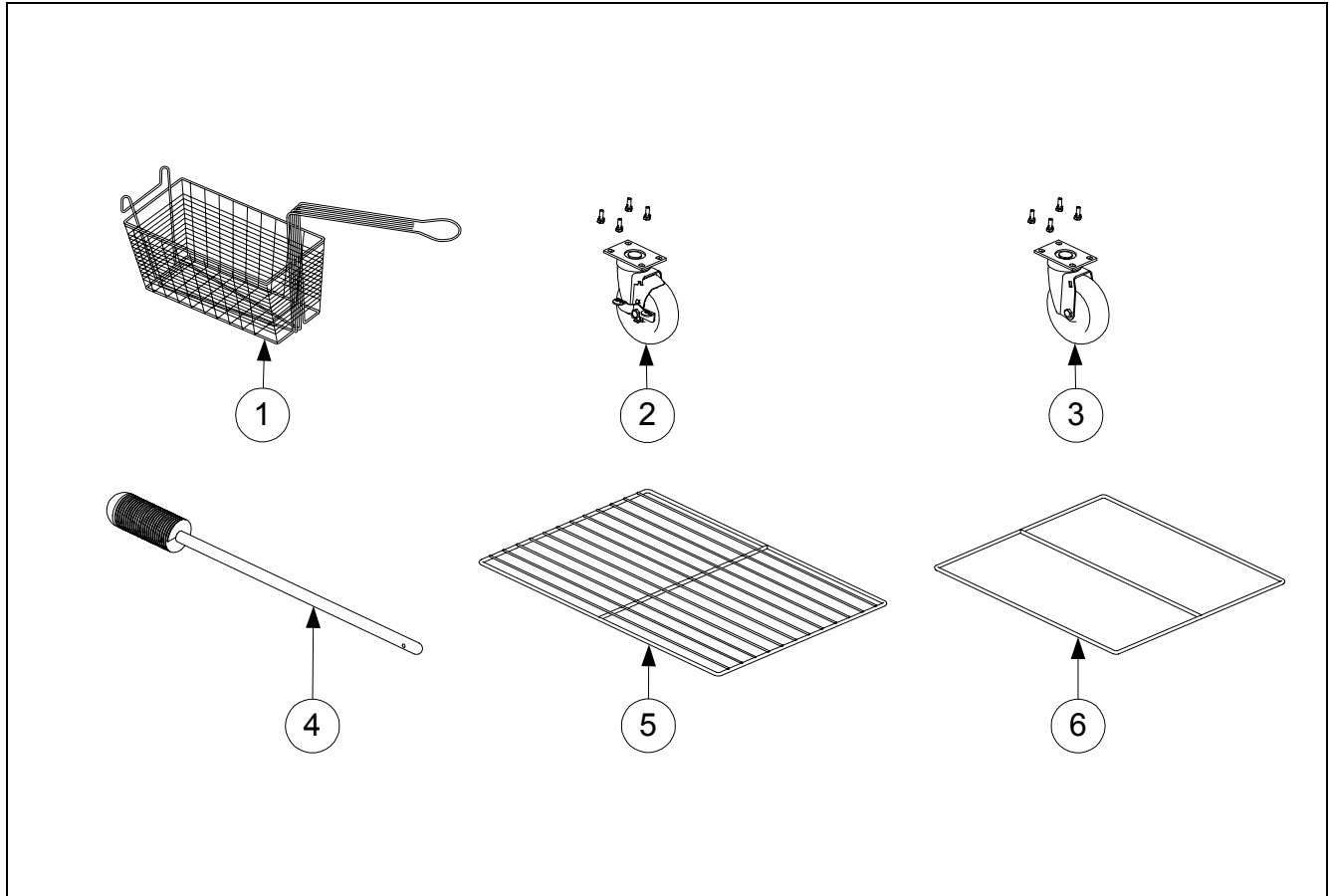

Item	Part Number	Description
1	803-0306	Fry Basket, Twin Basket
2	826-1118	Caster, 5" - With Brake (Mounting Hardware Included)
3	826-1117	Caster, 5" - W/O Brake (Mounting Hardware Included)
4	803-0209	Brush, Frypot
5	803-0348	Rack, FP36 Basket Support
	803-0349	Rack, FP28 Basket Support
6	803-0350	Screen Assembly, FP28/36 Basket

2.2 Basket Lift Assembly (Modular) and Related Components

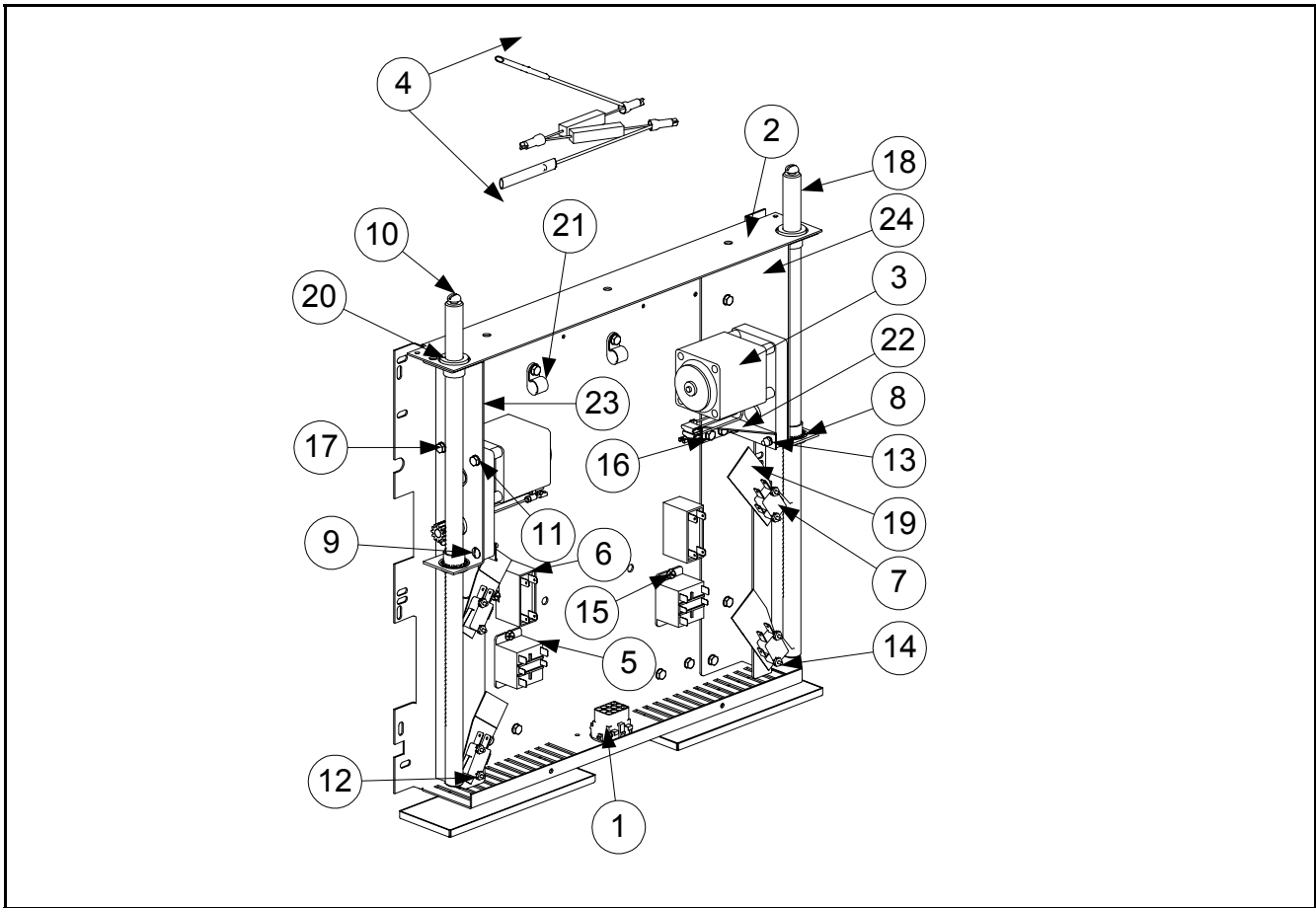

Item	Part Number	Description
1	807-0159	Connector, 12-Pin
2	200-6455	Mount, Modular Basket Lift
3	806-5964	Motor Assembly, Modular 120V Basket Lift
4	806-8530	Resistor Assembly, 120V
	807-2661	Resistor, 13 Ohm -120V, 10W (Part of 806-8530 Assembly)
5	807-1683	Relay, 12 Vdc
6	807-2133	Capacitor, Motor Run 12.5 mfd 250 VAC
7	807-2572	Microswitch, Formed End
8	809-0082	Ring, 3 /4 Truarc ZP
9	809-0111	Screw, 8-32x1 Tr SI HD ZP
10	809-0127	Screw, 1/4-20x1/2 Rd SI HD NP
11	809-0186	Washer, #8 Lock External Tooth
12	809-0237	Nut, 4-40 KEPS Hex w/Ext Tooth
13	809-0247	Nut, 8-32 Hex ZP KEPS
14	809-0354	Screw, 4-40x3/4 Pn SI Hd Zp
15	809-0361	Screw, Drill #8x1/2 Hx Hd Zp
16	809-0412	Screw, #10-1/2 Hx Washer Hd NP
17	809-0503	Screw, 8-32x1/2 Hx Zp

Item	Part Number	Description
18	810-1012	Rod, Modular Basket Lift
19	812-0442	Insulation, Safety Drain Box
20	813-0035	Bushing, Bronze Bunting .641/.640 ID
*	814-0015	Ty Wrap
21	816-0033	Ty Wrap Screw Mount #8 Screw
22	900-5529	Gusset, Motor - Modular B.L.
23	902-8499	Chassis, Right-hand Basket Lift
24	901-8499	Chassis, Left-hand Basket Lift
*	WIR0597	Wire Assembly, FP28/36S Mod Bb 120V
* Not Illustrated		

2.2 Basket Lift Assembly (Modular) and Related Components (cont.)

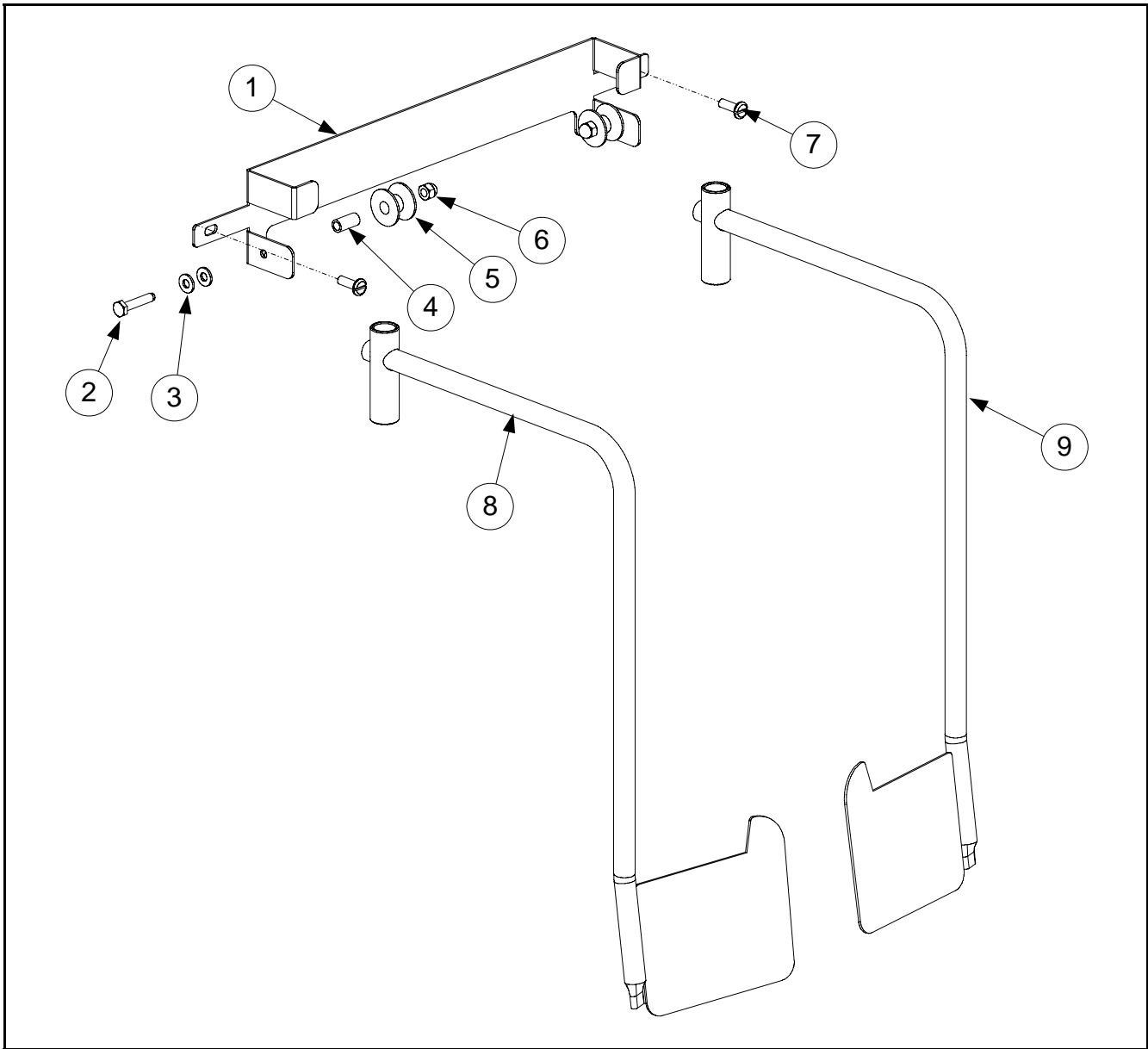

Item	Part Number	Description
1	106-4312	Roller Assembly, Bracket
2	809-0508	Bolt, 1/4-20 x 1-1/4" Hex Head S/S
3	809-0190	Washer, Flat- 1/4" S/S
4	810-0374	Spacer, Tubular Basket Lift Roller
5	810-0194	Roller, Basket Lift
6	809-0047	Nut, Cap- 1/4-20 S/S
7	809-0402	Screw, 1/4-20 x 1/2" Round Slotted S/S
8	823-4645	Basket Lift Arm- Left
9	823-4646	Basket Lift Arm- Right

2.3 Cabinetry and Related Components

2.3.1 Cabinetry

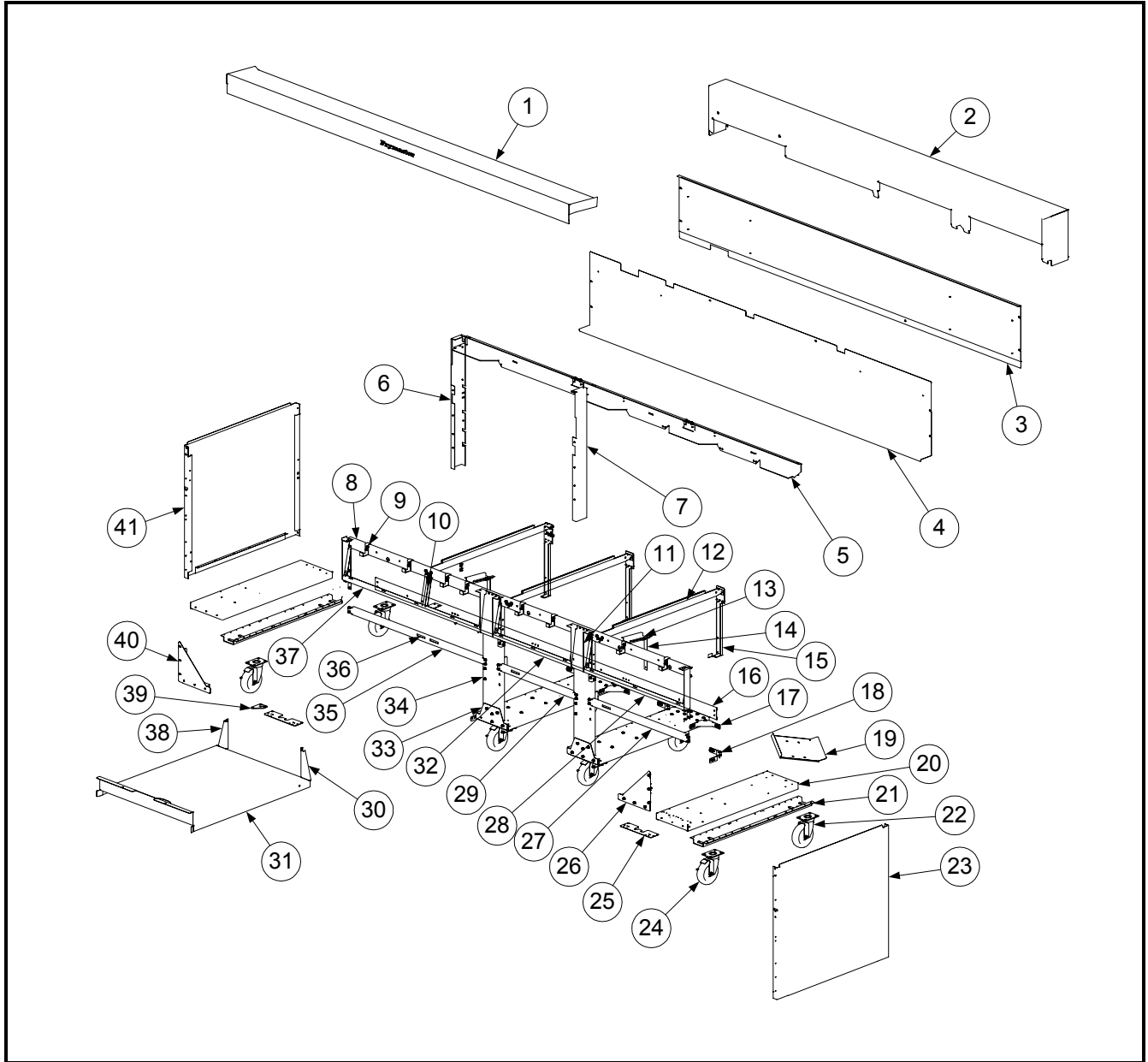

Item	Part Number	Description
1	106-3811	Topcap Assembly, FP128/236S
2	106-3815	Housing Assembly, FP128/236S Tilt
3	200-6528	Back, FP128/236S Upper Cabinet
4	200-6529	Back, FP128/236S Lower Cabinet
5	200-6494	Brace, Rear Horizontal Cabinet
6	106-3752	Upright Assembly, LH Rear Enclosure
*	106-3753	Upright Assembly, RH Rear Enclosure
7	202-6337	Upright, Rear Enclosure
8	200-6493	Brace, Cabinet Front Horizontal
9	106-3698	Brace Assembly, Computer
10	200-6037	Bracket, Center Control Panel
11	210-6102	Spacer, Computer Panel
12	200-6008	Divider, Cabinet
13	210-6151	Stiffener, Topcap
14	200-6152	Bracket, Topcap Tie-Down
15	200-6011	Bracket, Rear Support
16	106-3923	Channel, Rear Cabinet Base
17	201-6292	Brace, LH Rear Base Channel
18	202-6292	Brace, RH Rear Base Channel
19	200-6726	Plate, Filter Pump Mounting
20	200-6017	Channel, Cabinet Base
21	823-4516	Leg Channel
22	810-0356	Casters 5" Wheel W/O Brake
23	212-6020	Side, RH Cabinet
24	810-0357	Casters 5" Wheel W/Brake
25	200-6376	Plate, Door Hinge Mounting
26	202-6335	Gusset, RH Cabinet Channel
27	200-6257	Support, Front Cabinet Cross
28	106-3648	Frame Assembly, Single Control Panel
29	200-6500	Support, Front Cabinet Cross
30	202-6593	Bracket, Filter Pan Cover Mounting
31	210-6597	Lid, Filter Pan
32	106-3794	Frame Assembly, Control Panel
33	200-6094	Gusset, Lower Cab Middle
34	200-6090	Post, Vertical Cabinet
35	200-6109	Support, Front Cabinet Cross
36	810-2346	Magnet, Door
37	106-3647	Frame Assembly, FP28/36S Control Panel
38	201-6593	Bracket, Filter Pan Cover Mounting
39	210-4064	Hinge, Door
*	210-6343	Hinge, Door
*	810-1508	Hinge, Door Universal
40	201-6335	Gusset, LH Cabinet Channel
41	211-6020	Side, LH Cabinet
* Not Illustrated		

2.3.2 Door Components

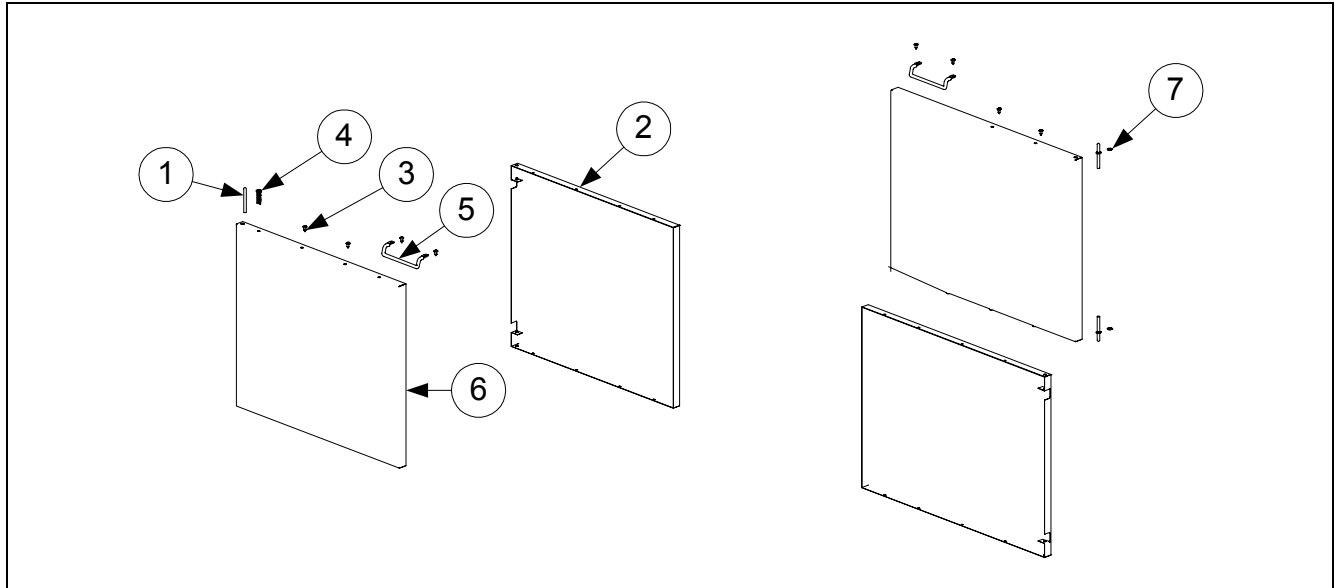

Item	Part Number	Description
1	106-0554	Pin Assembly, Door Slotted W/Keeper
2	200-6176	Liner, FP28 Cabinet Door (FP36 Liner is P/N 200-6282)
3	809-0266	Screw, #10-1/2 Phil TR HD ZP
4	810-0275	Spring, JCF Door Hinge Lock
5	810-1422	Handle, Wireform Door
6	824-1255	Door Weldment, FP28 Cabinet (FP28 Weldment is P/N 824-1270)
7	809-0413	Spacer, 1/4 X .160 8 Gauge Nylon

2.3.3 Dump Station Components

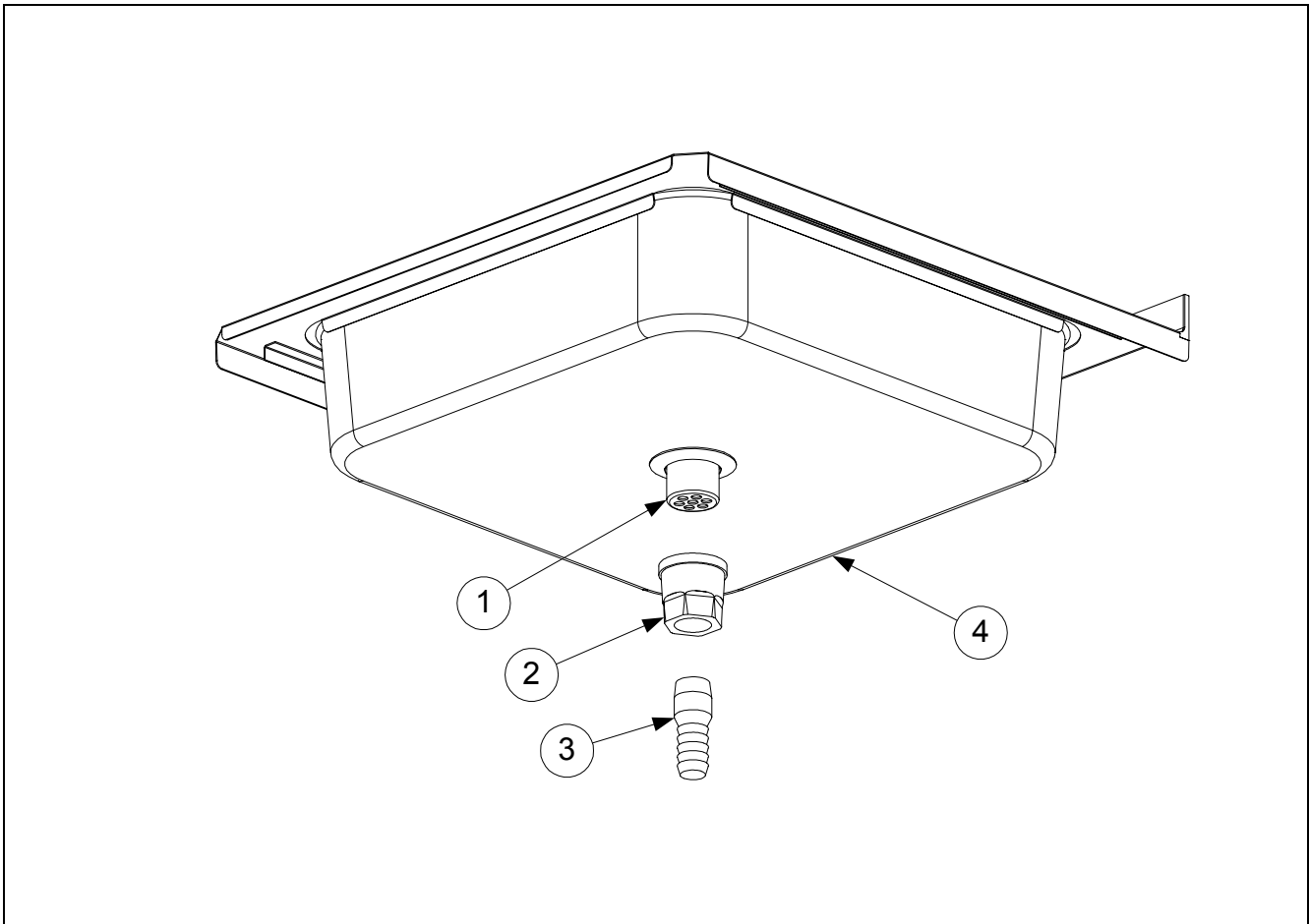

Item	Part Number	Description
1	813-0396	Drain, Sink 1 ½ NPS
2	813-0873	Reducer, 1 ½ NPS To 1NPT Blk Bell
3	813-0874	Fitting, 1"NPT X 1" ID X 1" BarbHose
4	823-4620	Holder W/A, Dump Station Pan
* Not Illustrated		

2.4 Computer and Related Components

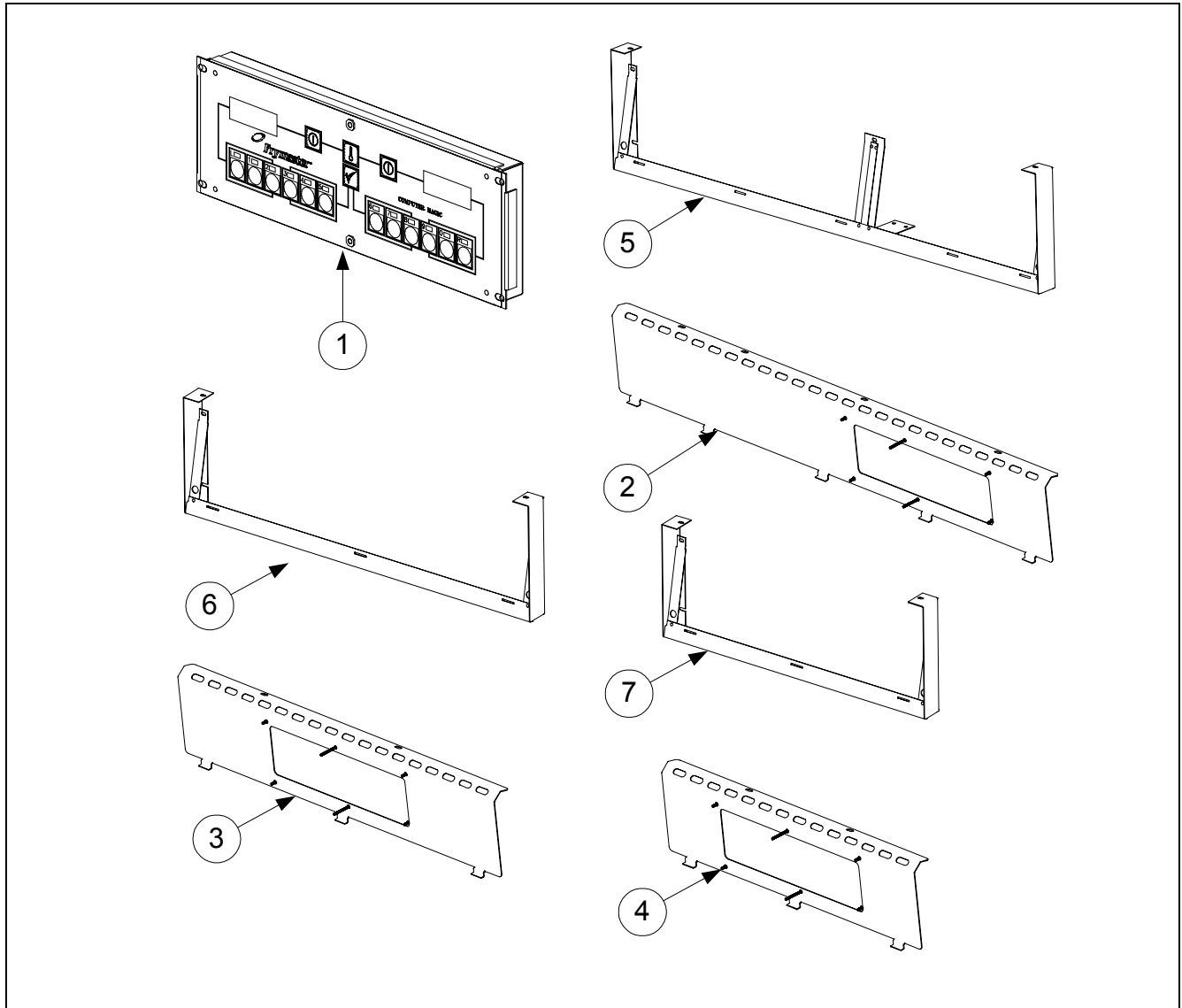

Item	Part Number	Description
1	106-0619	Computer, Standard CM3.5
2	823-4549	Bezel W/A, FP28 Control Panel Frame
3	823-4590	Bezel W/A, FP36S Control Panel Frame
4	823-4658	Bezel W/A, FP128/236S Control Panel Frame
5	106-3647	Frame Assembly, FP128S Control Panel
6	106-3648	Frame Assembly, FP136 Control Panel
7	106-3794	Frame Assembly, FP128/236S Control Panel

2.5 Contactor and Power Cord Box Assembly

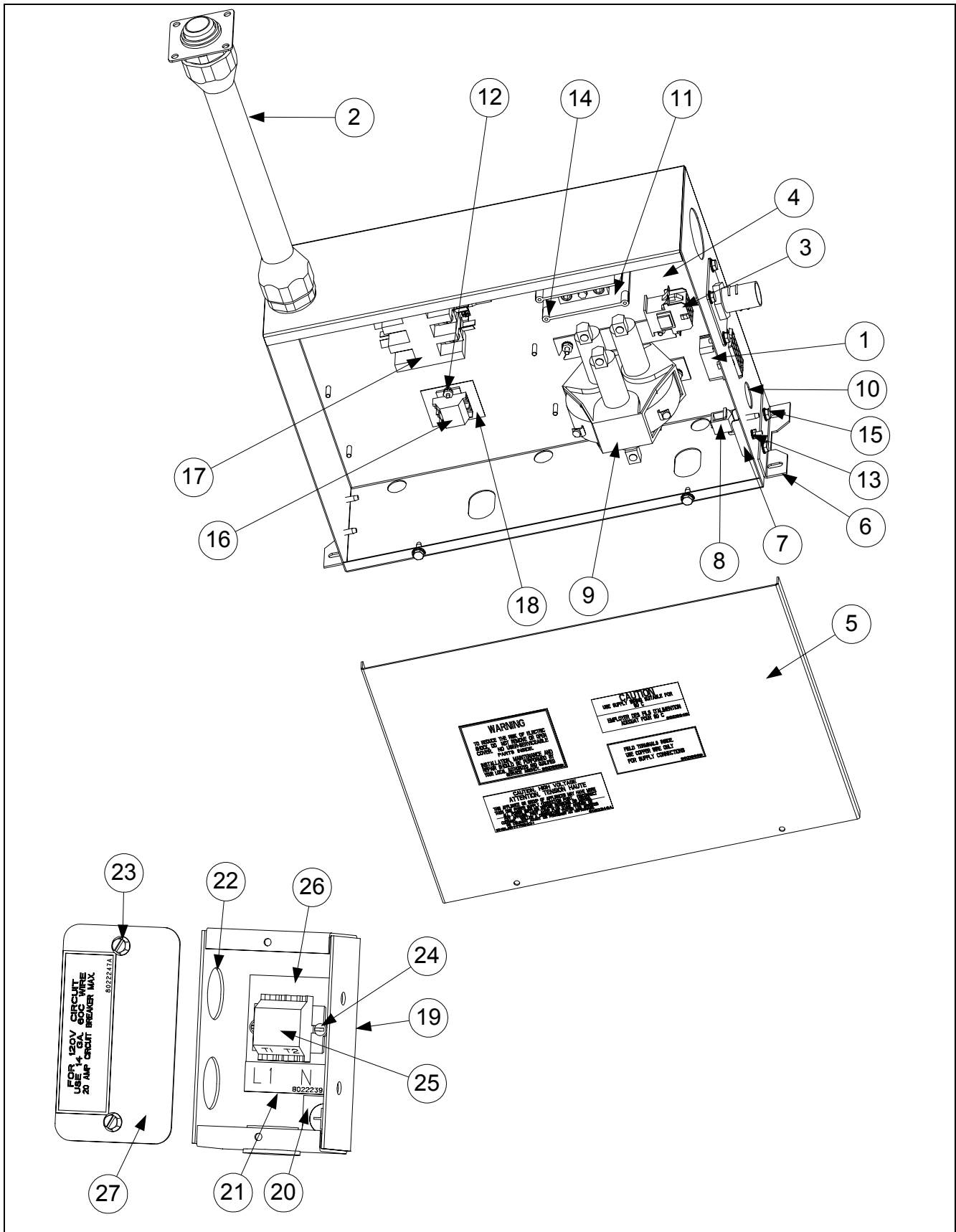

2.5 Contactor and Power Cord Box Assembly (cont.)

Item	Part Number	Description
	106-3672	Box Assembly, FP28/36S 480V LT Contactor
	106-3673	Box Assembly, FP28/36S 480V RT Contactor
1	106-3786	Harness, FP28/36S Contactor Box W/TB
2	106-3791	Cable Assembly, RH Contactor Box To Component box
3	106-3793	Harness, FP28/36S Element
4	106-4089	Box Stud Assembly, FP28/36 LT Contact (For RT Contact Use P/N 106-4090)
5	200-6156	Cover, 480V Contactor Box
6	200-6172	Bracket, Contactor Box Mounting
7	200-6809	Bracket, Ground Lug Holder
*	802-0742	Label, (Inside Cabinet) Ground
8	807-0070	Terminal, Ground Lug
9	807-0884	Contactor Mercury 240V 50A
10	807-1947	Plug, .875 Diameter (On LT Only)
11	807-3610	Block, Dean Terminal 1501-AL-9CU
*	809-0103	Screw, 8-32x1/2 TR SL HD NP
12	809-0237	Nut, 4-40 KEPS Hex W/External Tooth
13	809-0247	Nut, 8-32 Hex ZP KEPS
14	809-0250	Nut, 6-32 Hex ZP KEPS Ea
15	809-0412	Screw, #10 – 1/2 Hex Washer HD NP
16	810-1164	Block, 1 PLC Screwless Terminal
17	810-1202	Contactor, 40 Amp 3 Pole
18	816-0217	Paper, Insulating Terminal Block CE
	106-3964	Box Assembly, 120V Power Cord
19	200-6808	Box, FP28/36 120V Power Cord
20	802-0742	Label, (Inside Cabinet) Ground
21	802-2239	Label, Terminal Block (N & L1)
22	807-1947	Plug, .875 Diameter Dome
*	809-0237	Nut, 4-40 KEPS Hex W/External Tooth
23	809-0360	Screw, #8 X 3/8 Type B HX Washer HD ZP
24	809-0656	Screw, 4-40 X 3/8 Rd HD SL NP
25	810-1164	Block, 1 Plc Screwless Terminal
26	816-0217	Paper, CE Single Terminal Black Insulating
27	900-8016	Cover, Electrical Handy Box
*	WIR0598	Wire Assembly, FP28/36S Contactor Box

* Not Illustrated

2.6 Component Box Assembly

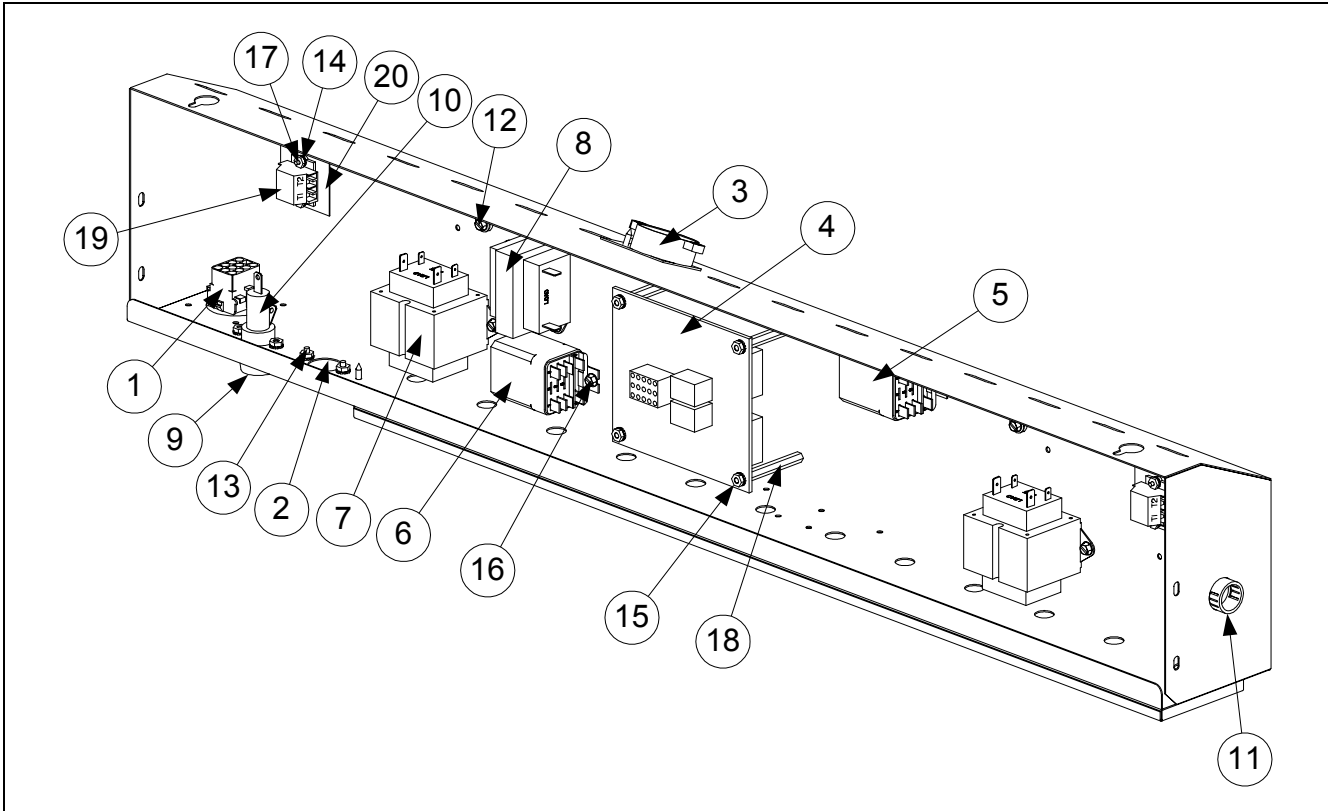

Item	Part Number	Description
	106-3691	Box Assembly, FP28/36S 480V LT Component
	106-3692	Box Assembly, FP28/36S 480V RT Component
	106-3795	Box Assembly, FP128/236S 480V MDL Component
1	106-3798	Harness Assembly, FP28/36S Component Box
2	200-6506	Plate, Component Box Fuse Cover
3	806-3660	Sound Device, High Output
4	806-7965	PCB Assembly, Interface (FV) Common Elect
5	807-0012	Relay 18 Amp 1/3 Hp 24V Coil (On LT Only)
6	807-0670	Relay, Midtex DPDT 24V
7	807-0800	Transformer 120 50/60-24V 50VA
8	807-0855	Transformer 120 50/60-12V 20VA
9	807-0922	Holder, Buss Fuse HPS
10	807-2278	Fuse, 20 Amp
11	807-3545	Bushing, Heyco, SB-875-11 (7/8")
12	809-0037	Clamp, Heyco #3327 Nylon Wire
13	809-0095	Screw, 6-32 X 3/8 TR SL HD NP
14	809-0237	Nut, 4-40 KEPS Hex W/Ext Tooth
15	809-0250	Nut, 6-32 Hex ZP KEPS
16	809-0361	Screw, Drill #8 X 1/2 Hex HD ZP
17	809-0656	Screw, 4-40x3/8 Rd HD SL NP
18	809-0963	Standoff, 6-32, 1/4 X 2.00 NP
19	810-1164	Block, 1 Plc Screwless Terminal
20	816-0217	Paper, Insulating Terminal Block CE
*	106-3800	Harness Assembly, FP28/36S Component Box Jumper (On LT Only)
*	WIR0599	Wires, FP28/36 480V LT Component Box
* Not Illustrated		

2.7 Filter Pan and Related Components - Built-in Filtration

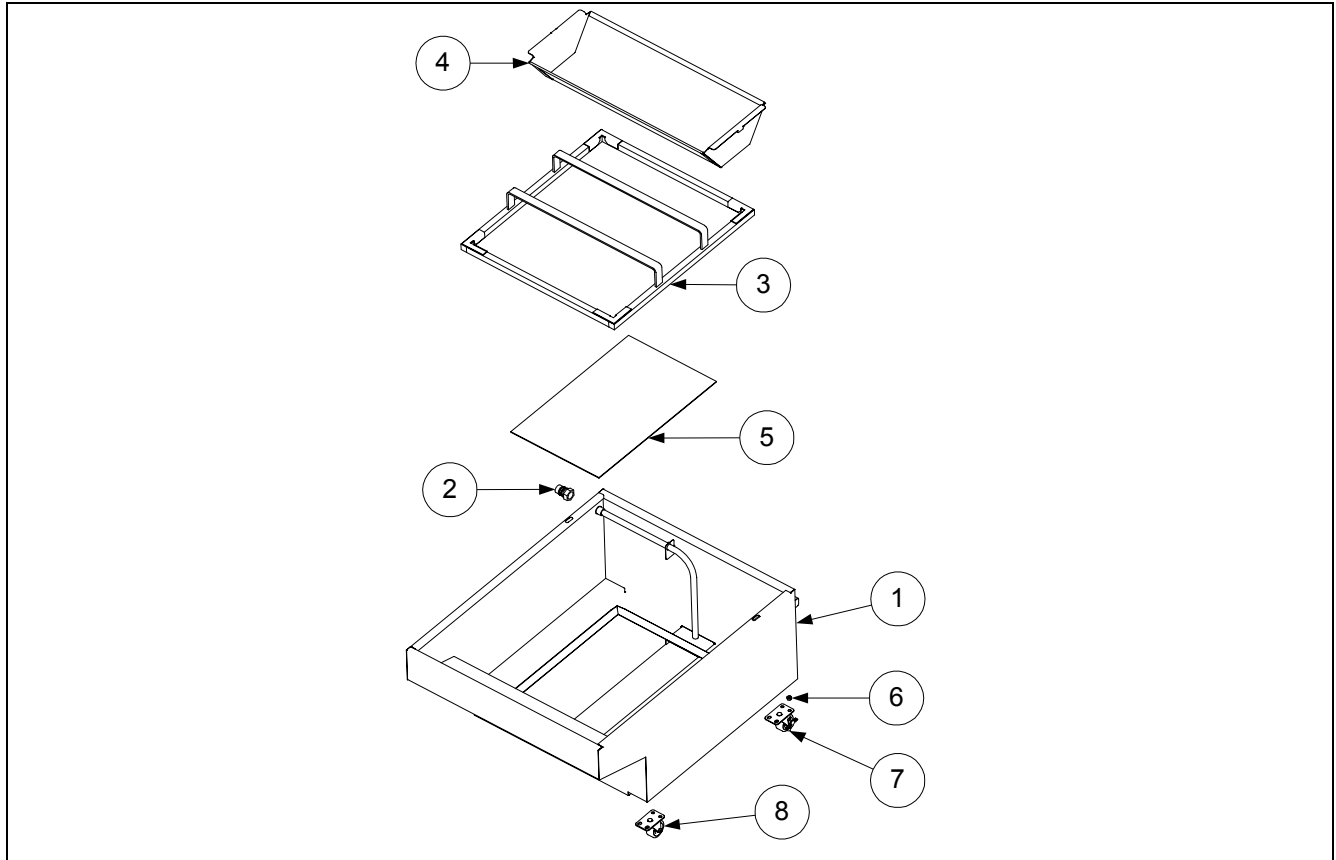

Item	Part Number	Description
1	106-3600	Pan Assembly, Filter
2	810-0487	Quick Disconnect, 1/2" Male
3	823-4619	Ring, Hold Down
4	823-4622	Tray, Filter Pan Crumb
5	900-8819	Screen, FP3 Sana Grid
6	809-0059	Nut, Grip 1/4" - 20 HX NP
7	810-0444	Caster, Swivel W/Brake
8	810-0006	Caster, Swivel

2.8 Frypot and Related Components

2.8.1 Frypot and Drain Valve Components

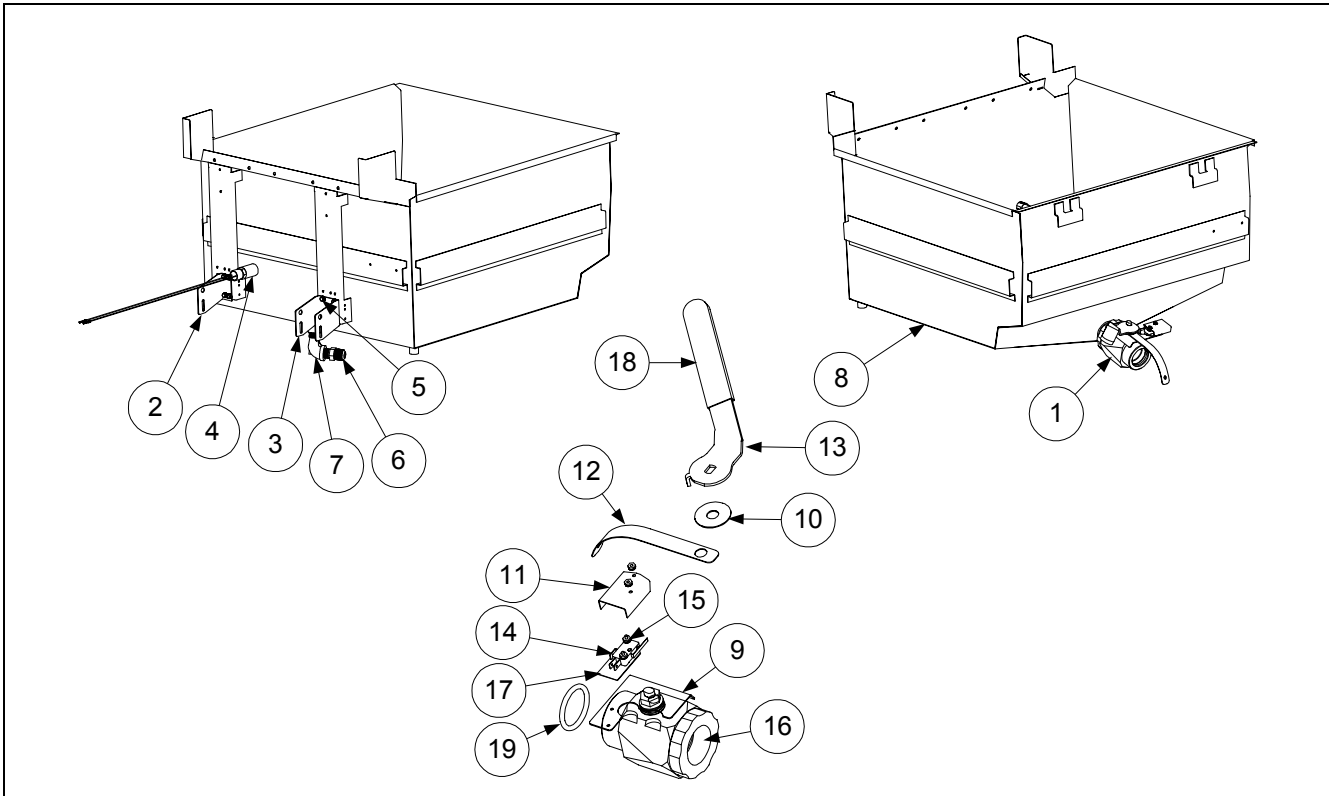

Item	Part Number	Description
	106-3763	Frypot Assembly, FP28 110 lbs
	106-3764	Frypot Assembly, FP36S 160 lbs
1	106-3756	Valve Assembly, FP28/36 Frypot Drain
2	210-6578	Bracket, FP28/36 Lower Spring
3	210-6765	Bracket, FP28/36 Lower Spring
4	806-8035	Thermostat Assembly, 435° Hi-Limit
5	809-0412	Screw, #10-1/2 Hex Washer HD NP
*	810-0297	Spring Element Lift B Blue 110# (Green 160# is P/N 810-1546)
6	810-1668	Adapter, Male 5/8"O.D. X 1/2 "
7	813-0165	EL, ST 1/2 NPT 90deg BM
8	823-4469	Frypot W/A, Walmart 110# (160 # is P/N 823-4473)
9	106-3745	Bracket Assembly
10	200-1617	Washer, Drain Microswitch K118G
11	200-5694	Cover, Switch Drain FPP
12	200-6345	Bracket, Drain Valve Mounting
13	200-6367	Handle, Drain Valve
14	807-2103	Switch, CE Micro Straight Lever
15	809-0237	Nut, 4-40 KEPS HEX w/external Tooth
16	810-2783	Valve, 1 1/2 Full Port Drain
17	816-0220	Insulation, RF Switch
18	816-0445	Sleeve, Drain Handle Red Plastic
19	816-0544	O-Ring, Seal

*	KIT6078SP	Float Switch Kit FP28 (Use KIT6079SP for FP36) Both kits include covers.
*	106-3972	Float Switch Assembly
*	809-0760	Nut, 8-32 HX SS Acorn
*	807-0705	Terminal Push On
*	812-1581	Sleeving, 22" x .263 PVC/Fiberglass
*	813-0619	Compression Fitting, 1/4" NPT x 5/16
*	823-4783	FP28 Float Switch Cover
*	823-4785	FP38 Float Switch Cover
Drain Associated Parts		
*	823-4846	3" Drain Dump
*	823-4670	3" Drain Tube, right side
*	823-4672	3" Drain Tube, left side
*	816-0625	3" Connecting Sleeve
*	809-0969	3" Clamp
* Not illustrated		

2.8.2 Oil Return Wand

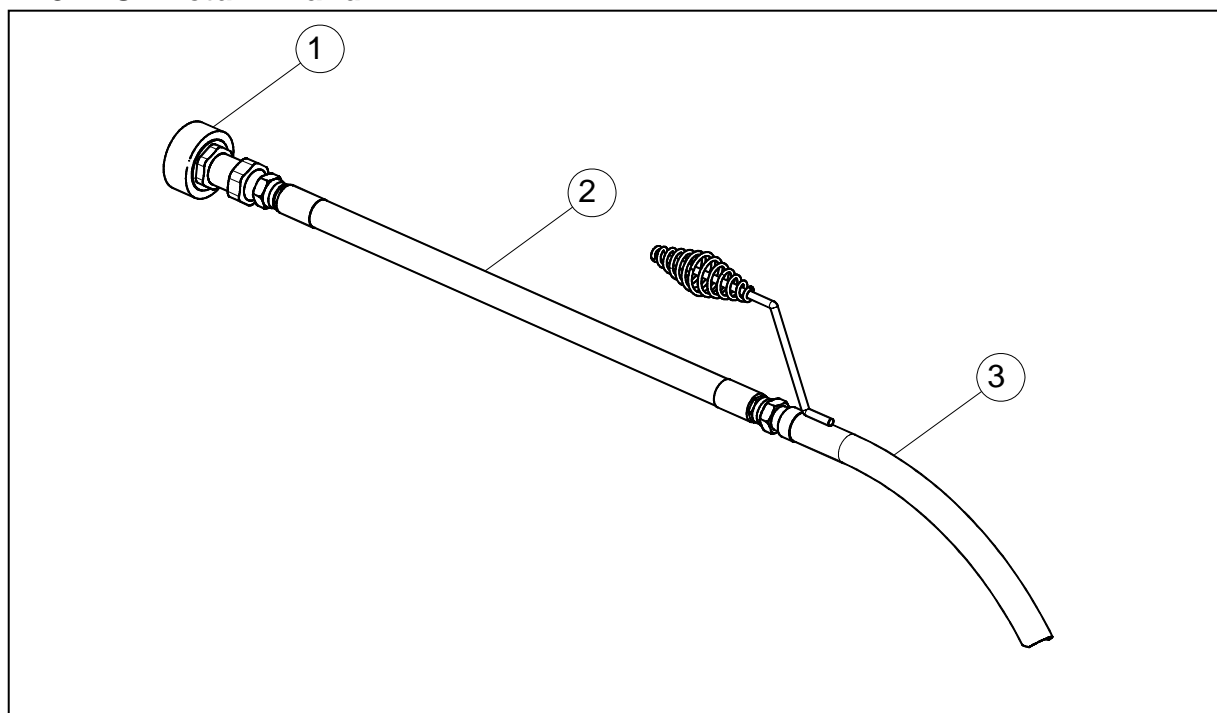

Item	Part Number	Description
	106-4395	Oil Discard Wand assembly
1	810-0490	Quick Disconnect, 1/2 inch female
2	810-1471	Hose
3	810-1091	Wand
* Not Illustrated		

2.8.3 Elements and Related Components

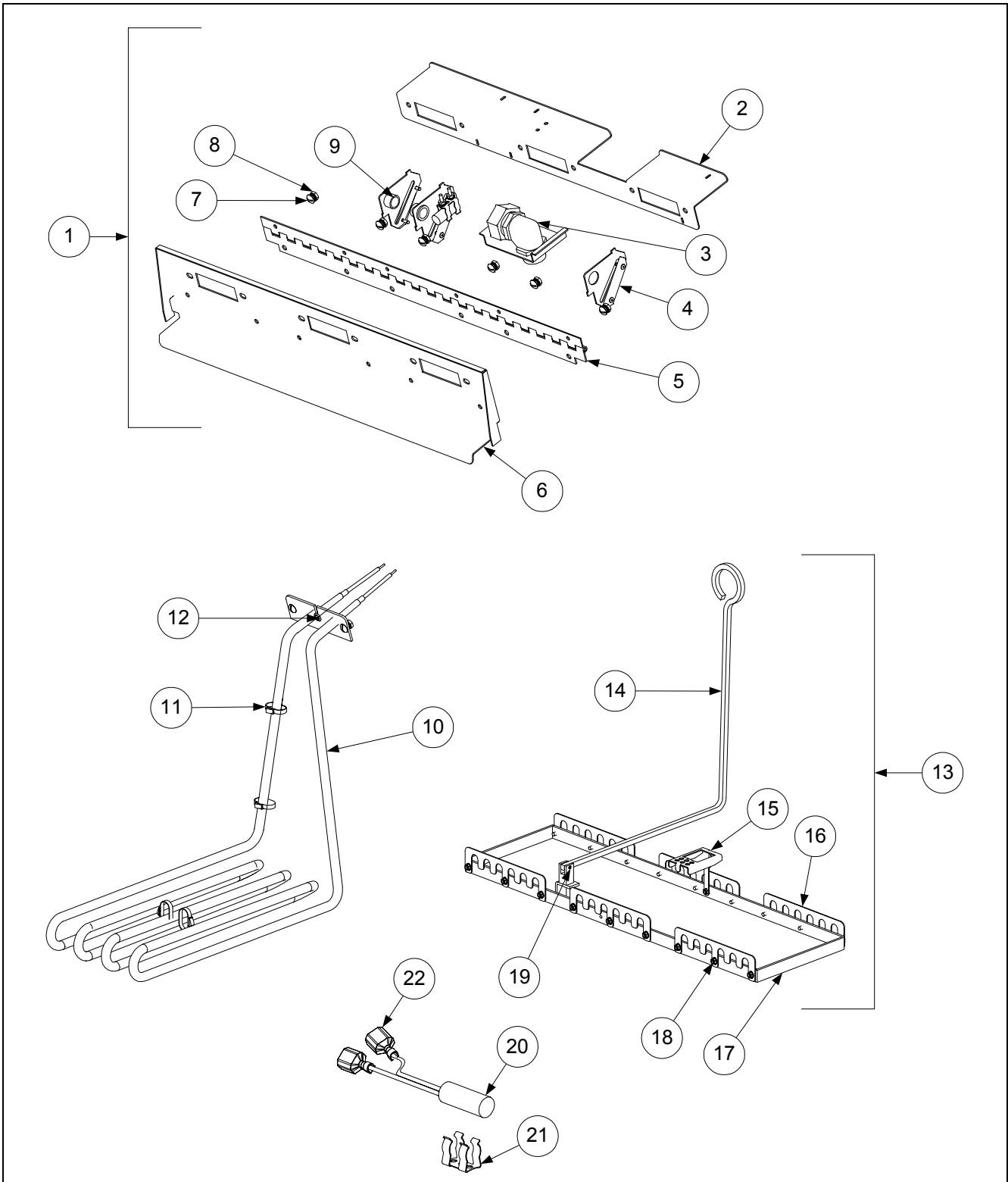

2.83 Elements and Related Components (cont)

Item	Part Number	Description
	106-3689	Element Assembly, FP28 480V 36.6 kW
	106-3867	Element Assembly, FP36 480V 11.9 kW
1	106-3690	Tilt Plate Assembly, FP28/36S (Includes Items 2-9)
2	823-4669	Bracket, Tilt Plate Spring
3	807-2071	Connector, 90 Degree ¾ Hub/Conduit
4	816-0214	Bar, Spring Slot Bracket
5	810-2751	Hinge, Stainless Steel
6	210-6186	Plate, Single Tilt
7	809-0117	Screw, #10-32x¾ TR SL HD SS
8	809-0256	Nut, KEPS 10-32 Hex ZP
9	807-0121	Bushing, Heyco Plastic
10	807-4009	Element, FP28/36S 480V 9.533 kW (For 11.9 kW Use P/N 807-4011)
11	809-0567	Tie Wrap, Metal
12	807-1025	Bushing, .375 X .188 Id
13	106-3772	Bar Assembly, 28 kW Element (Includes Items 14-19) (For 36 kW Use P/N 106-3765)
14	810-2792	Handle, 28 kW Element Lift (For 36 kW Use P/N 810-2768)
15	210-6425	Guard, 28 kW Temperature Probe (For 36 kW Use P/N 210-6401)
16	210-6424	Bracket, 28 kW Element Mounting (For 36 kW Use P/N 210-6225)
17	823-4621	Bar, 28 kW Element Clip Mounting (For 36 kW Use P/N 823-4614)
18	809-0518	Screw, #8-32 X ¾ Hex Head Slotted SS
19	810-1212	.125 X .50 Slotted Pin
20	806-6849SP	Switch, Tilt Safety
21	807-1570	Clip, Tilt Switch
22	807-1397	Terminal, Push-On- Fully Insulated
*	807-4026	Probe, 28 kW Temperature (For 36 kW Use P/N 807-4027)
*	816-0480	Plug .375 OD Dome
*	809-0874	Ty Wrap, Plastic- 4" (Operating Temperature 265°F)
*	809-0250	Nut, Keps- 6-32 Hex
*	809-0096	Screw, 6-32 x 5/8"- Binding, Slotted-Head
*	826-1374	Screw, #10 - ½ - Hex Washer Head (Qty: 25)
*	809-0766	Nut, SS- 10-32
* Not Illustrated		

2.9 Oil Return Assembly

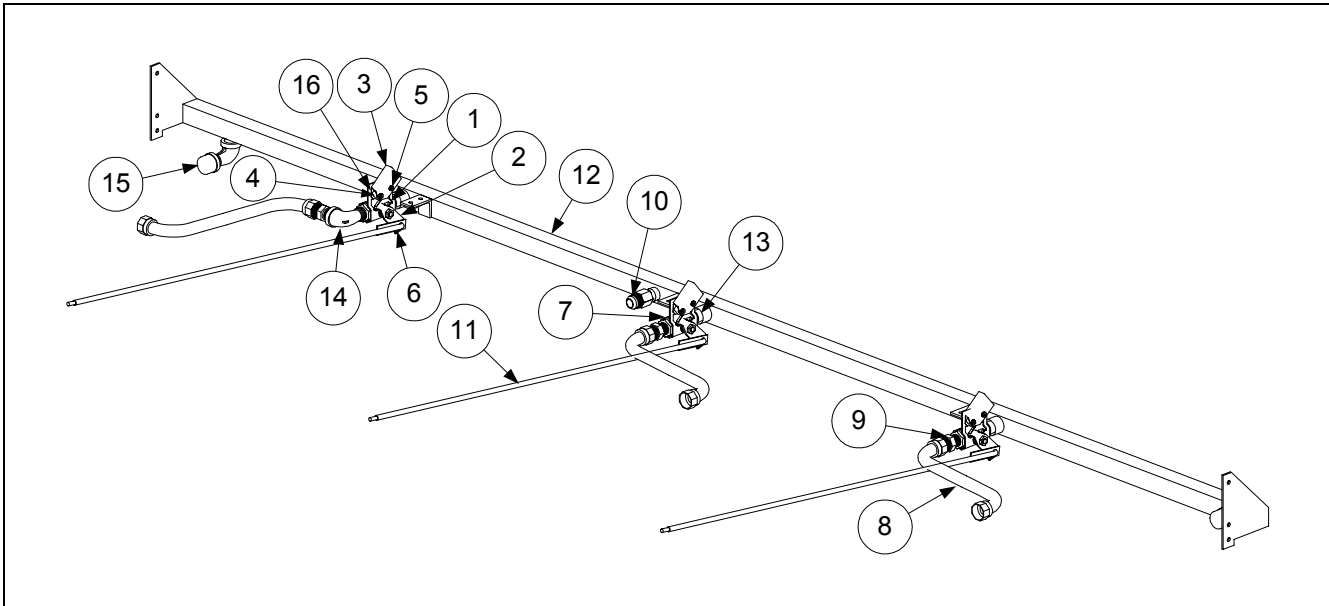

Item	Part Number	Description
1	106-3925	Bracket, FP28/36 1/2 " Valve Microswitch
2	200-4545	Handle, 1/2 " Valve
3	200-6799	Cover, Safety Switch
4	807-2103	Switch, Micro 3v1104d9
5	809-0237	Nut, 4-40 KEPS Hex W/Ext Tooth
6	809-0843	Cotter Pin Plated
*	809-0885	Washer, 3/8 X 1 X.083
7	810-0278	Valve, 1/2 " Ball
8	810-1057	Flexline, 5/8" X 13.00" Long
9	810-1668	Adapter, Male 5/8"O.D. X 1/2 "
10	810-1669	Adapter, 5/8 "O.D. X 1/2"Female
11	810-2766	Rod Assembly, Oil Return
12	810-2779	Manifold, Oil Return
13	813-0022	Nipple, 1/2 X Close NPT B.M.
14	813-0165	El, St 1/2 NPT 90 Degree B.M.
15	813-0469	Cap, 1/2 NPT BM
16	816-0220	Insulation, RF Switch

* Not Illustrated

2.10 Filter Pump Assembly

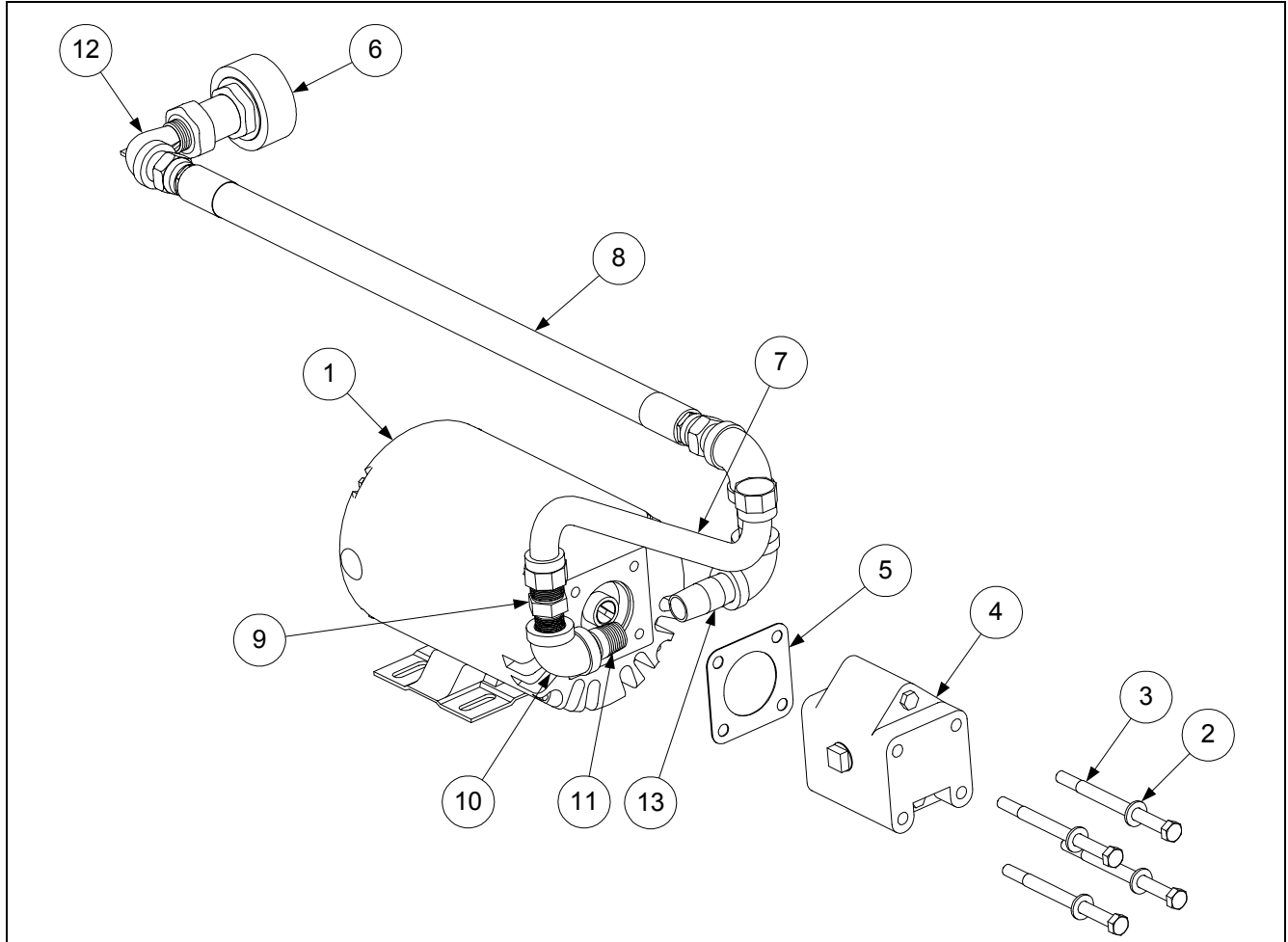

Item	Part Number	Description
	806-6034	Pump/Motor Assembly, 115V/60hz
1	807-1969	Motor, 115 V 60 Hz
2	809-0194	Washer, Flat 5/16
3	809-0514	Cap Screw, 5/16 – 18 HX HD
4	810-2716	Pump, Viking 4 GPM 2-Piece
5	816-0093	Gasket, Pump/Motor
6	810-0490	Quick Disconnect ½ " Female
7	810-1057	Flexline, 5/8" X 13" Long
8	810-1471	Hose W/Wand, FPH50 24"
9	810-1668	Adapter, Male 5/8"O.D. X ½ "
10	813-0062	Elbow, ½ 90deg BM
11	813-0087	Nipple, ½ NPT X 1 ½ BM
12	813-0165	El, ST ½ NPT 90 degree BM
13	813-0298	Nipple, ½ NPT X 2.0 BM
* Not Illustrated		



Enodis®

One Company, Countless Solutions

Frymaster L.L.C./Dean, 8700 Line Avenue, PO Box 51000, Shreveport, Louisiana 71135-1000
Shipping Address: 8700 Line Avenue, Shreveport, Louisiana 71106

TEL 1-318-865-1711

FAX (Parts) 1-318-219-7140

FAX (Tech Support) 1-318-219-7135

PRINTED IN THE UNITED STATES

SERVICE HOTLINE
1-800-551-8633

8196049

February 2005